



# TRAIL DESIGN STRATEGY SAN ANTONIO

December 2018



## CLIENT

City of San Antonio



CITY OF SAN ANTONIO  
**PARKS & RECREATION**

Xavier D. Urrutia  
Director  
City of San Antonio Parks &  
Recreation Department

Daniel Leal  
Project Manager  
City of San Antonio Parks &  
Recreation Department  
210.207.3004  
Daniel.Leal@sanantonio.gov

## PROJECT TEAM

Asakura Robinson (Project Lead)

asakura  
robinson

Margaret Robinson  
Principal-in-Charge  
512.351.9601  
margaret@asakurarobinson.com

Katie Coyne  
Project Manager  
512.351.9601  
katie@asakurarobinson.com

Big Red Dog (Project Subconsultant)





## **ABBREVIATION KEY**

LID - Low Impact Development

NRCS - Natural Resources Conservation Services

HWP Greenway - Howard W. Peak Greenway Trail System

SA - San Antonio

SARA - San Antonio River Authority

SWOT - Strengths, Weaknesses, Opportunities, and Threats

TCI - Transportation and Capital Improvements Department

TOD - Transit-Oriented Development

UTSA - University of Texas at San Antonio

VIA - VIA Metropolitan Transit



# TABLE OF CONTENTS

<b>1 Introduction.....</b>	<b>6</b>
<b>2 Stakeholder Engagement.....</b>	<b>10</b>
2.1 Stakeholder Meetings	12
2.2 Internal Meetings	14
<b>3 Site Analysis.....</b>	<b>16</b>
3.1 Regional Planning Context	18
3.2 Regional Parks System	20
3.3 Demographics	22
3.4 Environmental Context	28
3.5 Land Use and Transportation	36
3.6 Trail Use Frequency	40
3.7 Trail Capacity	42
<b>4 Trail Design Vision .....</b>	<b>44</b>
4.1 The Vision	46
4.2 Medina River	50
4.3 Salado Creek South	52
4.4 Salado Creek North	54
4.5 Leon Creek South	56
4.6 Leon Creek North	58
4.7 West Side Creeks	60





**5 Trail Interventions ..... 62**

**6 Design Toolkits ..... 66**

6.1 Medina River	68
6.2 Salado Creek South	72
6.3 Salado Creek North	76
6.4 Leon Creek South	80
6.5 Leon Creek North	84
6.6 West Side Creeks	88
6.7 Solar Orientation	92
6.8 Hardscape Toolkit	94
6.9 Low Impact Development Toolkit	100
6.10 Placemaking Interventions	110

**7 Master matrix ..... 112**



# 1 INTRODUCTION

The Howard W. Peak Greenway Trail System (Greenway) is a growing network of approximately 65 miles of developed multi-use and accessible trails. The Greenway trails wind through natural landscapes along many of San Antonio's waterways including Salado Creek, Leon Creek, Medina River, Westside Creeks (Apache, Alazan, Martinez, San Pedro, and Zarzamora), and the Tributary Creeks (Huesta Creek and Culebra Creek).

This Trail Design Strategy (TDS) was funded through the 2015 Sales Tax Proposition (Proposition 2 -Greenway Trail System) to enhance the general design standards of the Howard W. Peak Greenway Trail System.

The Trail Design Strategy establishes design principles, criteria for application, and enhanced features; which combine city-wide branded elements, with other features entitled to reflect the unique character of the neighborhoods in which they will be placed.

## PLAN OBJECTIVES:

- To provide an administrative vehicle to channel and harmonize current and upcoming design initiatives for the best possible impact on their surroundings and aligning them in a consistent way.
- To raise the quality of trails and make of this -already loved- infrastructure an even more valued city asset by residents, and eventually become an icon of San Antonio for visitors as well.
- To spark neighborhood revitalization, as a key component of urban regeneration, acting as a catalyst for infill redevelopment or neighborhood improvement in declining areas.
- To strategically apply Low Impact Development (LID) principles in an educational way, to showcase exemplary samples of best practices on water preservation and ecological design, for residents of all ages to enjoy and to get ideas from.





- To create a bolder city-wide vision for the entire Trail System, by thinking globally first, and acting locally then, in a coherent and consistent way, so each action/location speaks of the system and vice-versa.

To meet these objectives, this document is organized into six sections summarized as follows:

## STAKEHOLDER ENGAGEMENT

This section of the document outlines various meetings and workshops held between the consultant team, key Parks and Recreation Department stakeholders, stakeholders from other City of San Antonio Departments and allied entities, and the City of San Antonio’s Linear Creekway Parks Advisory Board.

## SITE ANALYSIS

The Site Analysis section includes pertinent information at a regional scale including an analysis of the regional planning context, demographic information, environmental context, land use and transportation, and trail use and capacity data. Each component of this section also includes a “Design Relevance” write-up aimed at acknowledging how to utilize information from the analysis section in applying the design strategies recommended in later chapters.

## TRAIL DESIGN VISION

The Trail Design Vision section includes further background on the Howard W. Peak Greenway program goals, the objectives of the Trail Design Strategy document, the criteria and approach used to determine design strategies, consideration of various recommended trail typologies based on frequency of use and population density, and an analysis of distinct “Character Areas” throughout the system.

## TRAIL INTERVENTIONS

The Trail Interventions section is the first section to outline the baseline recommended design characteristics of the future Howard W. Peak Greenway system. Within this section, trail widths

are recommended based on a preliminary analysis of necessary capacity needs for different sections of the trail and a comprehensive review of other cities’ greenway trail width guidelines. This section also introduces the concept of Tier 1 and Tier 2 trailheads and preliminary criteria for understanding how different variables should be used to prioritize trailhead investments.

## DESIGN TOOLKITS









The Design Toolkit section of this document is a result of the careful study of techniques appropriate for San Antonio based on both Stakeholder input and the Site Analysis, framed within the context of the larger Trail Design Vision. Within this section, site furnishings, hardscape elements, low impact development (LID) features, and other potential interventions are outlined in detail.

## MASTER MATRIX

The final section of this document condenses the design toolkits into a matrix describing appropriate application at Tier 1, Tier 2, and corridor sites while also tying items specific to certain Character Areas to their corresponding location.

## CHARACTER AREA MAP

*Character Areas of the Howard W. Peak Greenway System as recommended in the San Antonio Trail Design Strategy.*

-  Trail Complete
-  Trail Planned
-  Medina River
-  Salado Creek South
-  Salado Creek North
-  Leon Creek South
-  Leon Creek North
-  West Side Creeks
-  Mission and Museum Reach



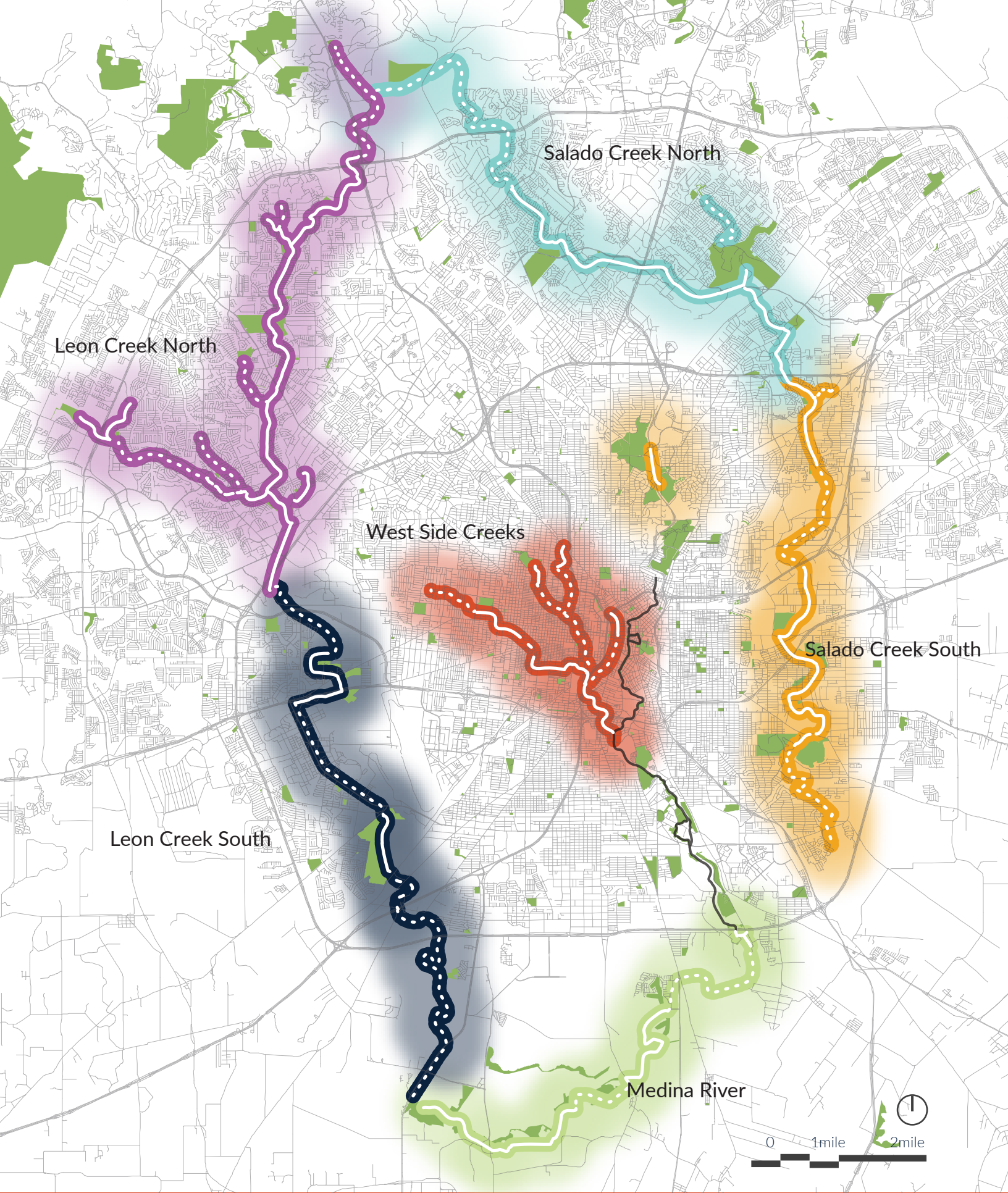

Leon Creek North

Salado Creek North

West Side Creeks

Salado Creek South

Leon Creek South

Medina River



## 2 STAKEHOLDER ENGAGEMENT

Throughout the project, the project team met with key stakeholders in a number of workshops. First with a group of key stakeholders from various City of San Antonio departments and partner organizations and second with the Linear Creekway Parks Advisory Board, each stakeholder provided valuable input on the opportunities and barriers to a successful future for the greenway system but also on how this document and future work on the greenways can align with other City programs, policies, and projects.

Additionally, Parks and Recreation Department Staff met together multiple times throughout the process to work toward consensus on key items related to this plan. The results of these meetings are outlined in the following pages.



T-1

FOOD TRUCKS → PROGRAMMING  
SPECIAL SHADE STRUCTURES  
EXEMPLARY DESIGN (LID, ETC)

LOCATION (MAIN ROADS)

PUBLIC ART

HERITAGE TREES

HIGHER EDUCATION / MEDICAL / RETAIL  
SURROUNDING FACILITIES / GROCERIES

LID PARKING > 25  
EDUCATIONAL OPPORTUNITIES  
GATHERING PLACE (OUTDOOR)

REGULAR PARKING < 25

COMMUNITY GARDENS

BUS STOPS

NEIGH. CONNECTIONS < 1 MILE W  
S ... BK

T-2

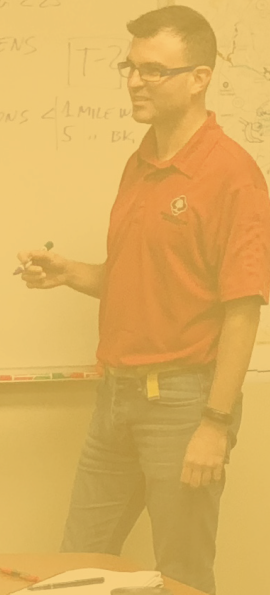

# 2.1 STAKEHOLDER MEETINGS

## STAKEHOLDER MEETING AND WORKSHOP

On the morning of June 26, 2018, stakeholders from the City of San Antonio, Bexar County, San Antonio River Authority, and other local entities, met with the consultant team at the Phil Hardberger Park Urban Ecology Center in San Antonio to learn more about the Trail Design Strategy and engage in a workshop identifying opportunities for cross-collaboration.

After an introduction of the project, the attendees, which were already seated in four groups according to potential for cross-department collaboration, were then asked to convene a discussion around several prompting questions. Each table was facilitated by either the consultant team or Parks and Rec., who led the discussions and took notes on large boards.

### GROUP A1

This group had representatives from Metro Health, VIA, parks, and TCI. They identified important ways greenways can support transportation through connectivity to nodes such as park and rides and bus routes. They identified the connection between



O.P. Schnabel, University of Texas at San Antonio, and the Ingram Park and Ride as good examples to draw upon. They said that translation services and public input from diverse groups would help improve equitable distribution and design of greenways.

### GROUP A2

This group had representatives from VIA Metropolitan Transit, the Office of Sustainability, and Transportation and Capital Improvements. Much of the initial discussion was centered on creating better connections between transit, major activity centers, and the larger transportation network. Coordination between greenways and capital projects at the earliest possible planning stage was identified as a crucial action to improve greenway connections.

### GROUP B1

This group included representatives from SARA, Public Art San Antonio, Planning and TCI. They first identified gaps in funding, maintenance and understanding of LID design features that are crucial in sensitive riparian areas. They suggested more collaboration in creating criteria for path placement to minimize environmental impact and maximize connectivity.

### GROUP B2

This group included representatives from SARA, Planning and TCI. They identified the opportunity to put trails outside of floodplains, referencing Dallas. They identified potential criteria for tier 1 & 2 trails, which include street connections, regional centers, and references in subarea plans. They identified



collaborative gaps between VIA, Military Planners, CPS, and others. They suggested amenities such as those at The Rim.

## LINEAR CREEKWAY PARKS ADVISORY BOARD MEETING

On June 26, 2018, the Linear Creekway Parks Advisory Board convened to learn more about the Trail Design Strategy and engage in a discussion of their insights regarding the trail system. After a brief presentation and some discussion, the meeting proceeded into a SWOT (Strengths, Weaknesses, Opportunities, Threats) analysis activity.

### STRENGTHS:

The board recognized the strengths of the trail system. Mr. Greg Hammer, chairman of the board, commented, “It’s on the right side on every issue. It has been a tremendous thing for San Antonio.” Specifically, the board discussed how the trail adds green space, improves health outcomes, and provides benefits for residents, visitors, businesses, and developers. The trail system was identified as an important asset to the community, providing healthy, free recreation across a large portion of the city. Additionally, the current and past sales tax initiatives which fund the system have been supported by the voting residents of San Antonio, indicating a reliable funding source.

### PERCEIVED WEAKNESSES

The board identified the need for a more consistent design and better connectivity throughout the system. Additionally, trail safety arose as an issue to be addressed.

### OPPORTUNITIES

Several opportunities were identified throughout the discussion, especially regarding connectivity, funding and consistent design. The trail’s growing popularity means that developers are now asking to connect directly to nearby trails. This presents an opportunity for the trail-oriented development

strategies outlined by The San Antonio Tomorrow Comprehensive Plan. Additionally, significant opportunities are apparent for connection to the greater transportation system as VIA begins its major push to improve transit across the City. The board also recommends the broadening of language to allow for trails to be built in minor tributaries and outside of the creeks all together.

### THREATS

The major threat currently seems to be that the trails could become a victim of their own success. Overcrowding, initial poor perceptions by neighborhoods, and multi-modal conflict were the main threats identified. Funding is currently a strong point, but there is concern that as the transit system grows, their sales tax funding could be diverted if the trail system is not recognized as an integral part of a multi-modal transportation system.

### CHARACTER AREAS

The meeting concluded by identifying major “Character Areas” that could express unique attributes along the trail. The board suggested highlighting the ecological diversity along the trails. They identified Character Areas such as the Missions World Heritage Sites and downtown. Other Character Areas that have not yet been highlighted include Olmos Creek, Fort Sam Houston, Mitchell Lake, and Salado South. These suggestions were taken into account for the identification of Character Areas in this strategy document.



# 2.2 INTERNAL MEETINGS

## CONTEXT IDENTIFICATION WORKSHOP

On June 5th, 2018, Daniel Leal convened a workshop of Parks and Recreation Department staff including: Brandon Ross, Agdel Rivera, Samuel Sanchez, Christopher Arrigo, Adelyn Alanis, and Andrew Zapata.

The workshop was conceived as a focused discussion group, around the topic of Tiers, which seeks to differentiate better between Tier 1, meant to act as landmarks, places that would draw people to them; versus Tier 2 locations, that are meant to be nodes or connectors to nearby neighborhoods and therefore, have a much more local scale.

### PROJECT TASKS

This exercise corresponds to Client's direction on tasks 2.1 and 2.2. Consultants took these ideas into consideration and expanded upon them for recommendations in this document.

Existing Tier 1 locations. As a team, we identified existing places that somehow, are already acting as "tier 1" places; maybe not in full, but definitely in a perceivable way. Tier 2 would be the rest.

- Leon: Valero, O.P. Schnabel, Crystal Hills, Ingram Transit Center. Pearsall in future expansions, too.
- Salado: Voelcker at Hardberger Park, Tobin trailhead, Southside Lions Park.
- Medina River: Natural Area trailhead.



- Westside: Elmendorf Lake Park.

### TIER 1 ELEMENTS

They combine some features that we are already using, but also incorporating others that could be explored in the future. Consultants took these ideas into consideration, along with others gathered in the project process.

- Exemplary design (setting an example to the public, in water conservation, butterfly protection, a San Antonio for the 21st century, etc.).
- Strategic location, close to highways and main roads.
- Public Art, to bring exceptionality and uniqueness.
- Heritage trees. If pre-existent, the design should acknowledge and enhance them.
- Proximity to Higher Education centers, medical hubs, major retail, and/or groceries (commuting use).
- Proximity to recreational facilities, usually within the same park (recreational use).
- Enhanced parking, in size (25 spaces and above) and in materials (LID), to contrast with the Tier 2 ones (conventional).
- Special/ differentiated shade structures.



- Educational spaces.
- Outdoor gathering spaces (can be the same as educational)
- Playgrounds, if allowed by funding source.
- Dining opportunities, such as food trucks.
- In a larger scheme of things, start programming, special events, marathons, , temporary exhibits, etc.

## TIER 2 ELEMENTS

They combine features that we are already using, but also others that could be incorporated or explored.

- Main purpose is connecting to the adjacent neighborhood (increasing WalkScore).
- Parking < 25 spaces, conventional materials.
- Community gardens.
- Site furniture.
- Water fountains.
- Small landscaping.
- Bus stops (coordination with VIA needed).

Other elements could fall under any of both categories, such as repair stations, portable restrooms, security cameras, emergency call boxes, etc. Their location is usually more dependent on the distance to the next one and available budget, rather than the tier categorization itself.



# 3 SITE ANALYSIS

The City of San Antonio's diverse environmental, cultural and economic conditions require close study to inform design standards that will responsive to the conditions across the City. Connections between major population centers, existing green spaces, and transportation infrastructure must be identified to maximize the effectiveness of the trail system. Meanwhile, environmental conditions such as flood potential, canopy cover, and soil types provide vital information used to determine the appropriate design for individual trail segments.

The following section includes maps and visualizations of this important site condition information for the entire trail system, including built segments out of the scope of this document, to provide a complete picture of the conditions on the ground. The analysis was typically conducted for the area within a 1 mile buffer of the trail. The analysis was conducted for all trails that are currently built, designed, or planned. Some areas, such as in Leon Creek South, are still only proposals, with no confirmed alignment - therefore they were omitted from this analysis.



# 3.1 REGIONAL PLANNING CONTEXT

## SA TOMORROW COMPREHENSIVE PLAN



SA Tomorrow Comprehensive Plan is the recently adopted (2016) comprehensive plan for the city of San Antonio, encompassing the City and surrounding area, with a planning outlook to the year 2040.

The plan identifies the major corridors and growth centers which will be the focus of improvements and development in the coming years, most of which directly intersect or relate to the HWP Greenway System.

## ALAMO AREA REGIONAL PLAN



The Alamo Area Regional Plan identifies transportation goals and specific improvements for the entire San Antonio metro area. The bicycle and pedestrian studies identify improvement priority hot-spots throughout the metro area, followed by detailed design recommendations. The study identifies many crucial opportunities to integrate the regional multi-modal transportation network with the HWP Greenway System.

## THE HOWARD W. PEAK GREENWAY TRAIL SYSTEM BRANDING & WAYFINDING SIGNAGE GUIDELINES



The document serves as a technical resource to guide parks and transportation agencies as they plan, design, and implement brand and wayfinding signage along the greenway trail system within the San Antonio metro area. It provides guidance for greenway trail brand applications, wayfinding element design, sign messaging, sign placement and the modification of the existing sign styles to create a unified signage system.

## SAN ANTONIO BIKE PLAN 2011



The San Antonio Bike Plan 2011 established the long-term vision for cycling in the City, including a 1,768 mile cycling network, comprehensive support facilities, advocacy programs and bike facility design guidelines.

The plan includes quantifiable goals, like integrating the larger cycling network with the off-street trail network where important benchmark targets are identified.



## VIA 2040 LONG RANGE TRANSIT PLAN



VIA Vision 2040, San Antonio’s public transit long range plan, dovetails strongly with SA Tomorrow Comprehensive Plan’s corridor and nodal growth plans while identifying specific improvements to the transit system to improve the experience and effectiveness of the transit system. The plan identifies major transit corridors and centers with their corresponding Trail Capacity and implementation priority. The transit centers include prioritization for connections to the City’s bicycle network.

The plan also outlines the characteristics of “Transit Oriented Development” (TODs), which promotes urban density near transit centers to reduce car trips and improve urban quality of life. The plan recommends that the TODs be well connected to multi-modal transportation options, including the off-street trail network.

## SAN ANTONIO PARKS SYSTEM PLAN



The SA Parks System Plan will guide future planning decisions on the expansion, capital improvements, and programming of the more than 240 City-owned parks and recreational facilities, 15,000 plus acres of green space and over 181 miles of trails. The plan is updated every 10 years with the last plan being adopted in 2006.

The plan will leverage the work and coordinate closely with the goals and policies outlined in the SA Tomorrow Comprehensive Plan. Such policies include: addressing gaps in pedestrian and bicycle access to parks, open space and recreation sites as well as investing in furthering the momentum of the City’s current river and trail investments for multi-use paths and multi-modal connectivity.

# 3.2 REGIONAL PARKS SYSTEM

## MAJOR PARKS ON HWP GREENWAY SYSTEM

The trail system intersects a number of major regional, city and neighborhood parks. These parks vary widely in ecology, use and size. Leveraging these parks as activity nodes, particularly for recreational purposes, will be crucial in the continued success of the system.

### DESIGN RELEVANCE

Parks throughout the City of San Antonio are major hubs for the HWP Greenway system and should be given special consideration as key locations for Tier 1 Trailheads, especially at the most well-used parks. Additionally, amenity gaps in particular parks throughout the City could be grounds for prioritizing greenway investments to help mitigate those needs.

McAllister Park



Southside Lions Park



Woodlawn Park, City of San Antonio



O.P. Schnabel Park



# PARKS AND OPEN SPACE

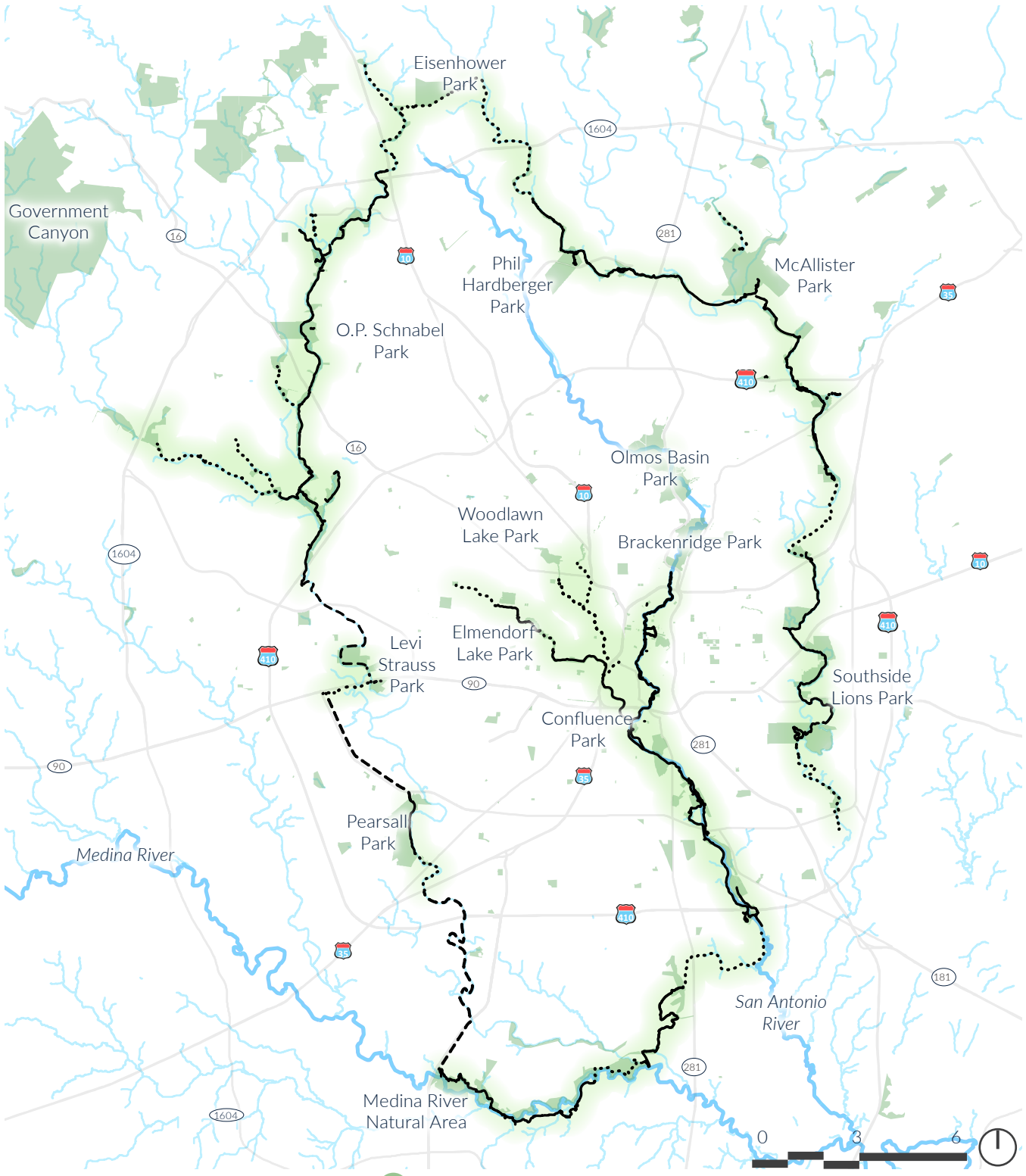

- Existing Trails
- ..... Trails Under Construction/Design and Approved Trails
- - - Potential Future Alignment
- Parks

Source: City of San Antonio



# 3.3 DEMOGRAPHICS

## DEMOGRAPHIC THEMES

### POPULATION GROWTH

San Antonio, like much of the Central Texas Region, is experiencing some of the fastest urban growth in the country. This growth is concentrated in multiple areas around the City, including around downtown, the far North (Stone Oak) area, and the far west sides. Because the trail system is largely confined to creek and river corridors, the system does not necessarily track with population centers or transportation corridors. This leaves some of the most densely populated areas of the City underserved by the trail system. As the City population grows, the trail system's role as transportation infrastructure as well as a recreational amenity will also increase.

### DEMOGRAPHIC TRENDS

Generally, the north side of San Antonio has held far more wealth than the south, west and east sides. This inequality can be traced to a history of Jim Crow racial segregation, economic redlining, unequal school funding and infrastructure investment concentrated on the north side. While the HWP Greenway Trails are hardly a solution to these system issues, it is vital that these conditions are taken into consideration to ensure equitable investment in the system moving forward.

In addition to the history of segregation, the City is also experiencing gentrification in central neighborhoods, particularly on the City's east side. It is important to take into account the role of infrastructure investment in the gentrification process, and to couple improvements and expansions to the greenway system with programs aimed at preventing displacement of longtime communities even as the neighborhoods evolve around them.

### TRACTS INTERSECTING WITH TRAILS

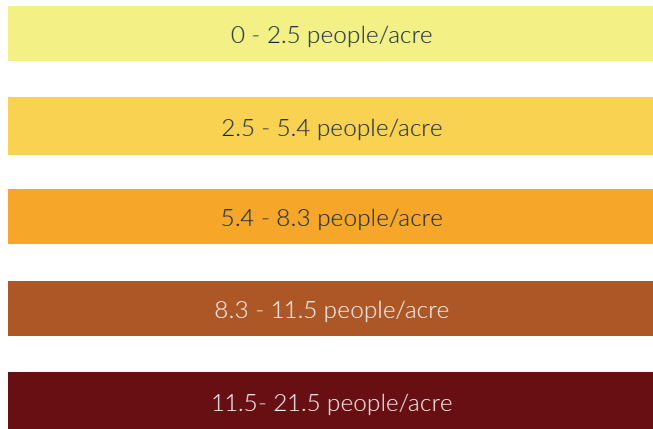
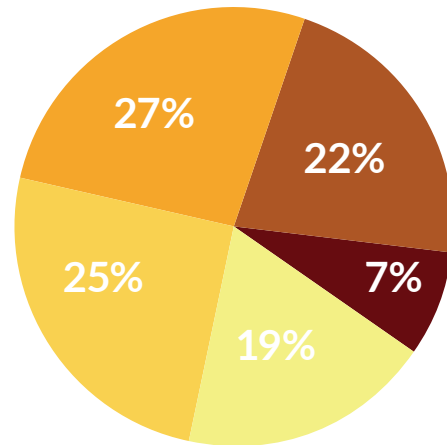

### DESIGN RELEVANCE

Population density often correlates with the frequency of use for trail systems nationally. Density should be a key consideration when determining locations for both Tier 1 and Tier 2 Trailheads throughout the system.



# POPULATION DENSITY NEAR TRAILS

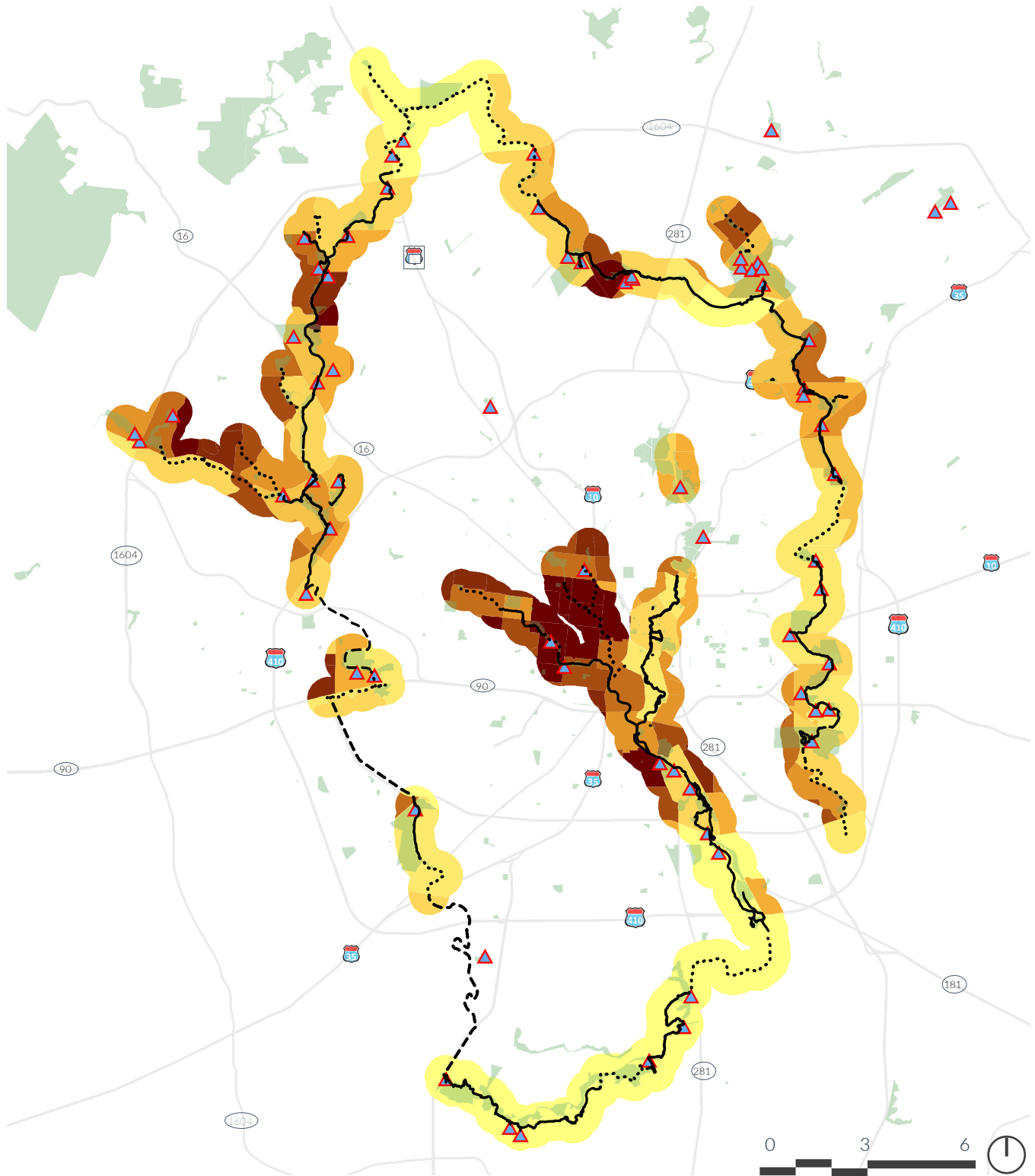

- Existing Trails
- ..... Trails Under Construction/Design and Approved Trails
- - - Potential Future Alignment

- ▲ Trailhead
- 1 Mile Buffer

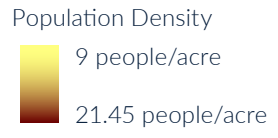

Source: ACS 2012-2016 5-year

# MEDIAN FAMILY INCOME NEAR TRAILS

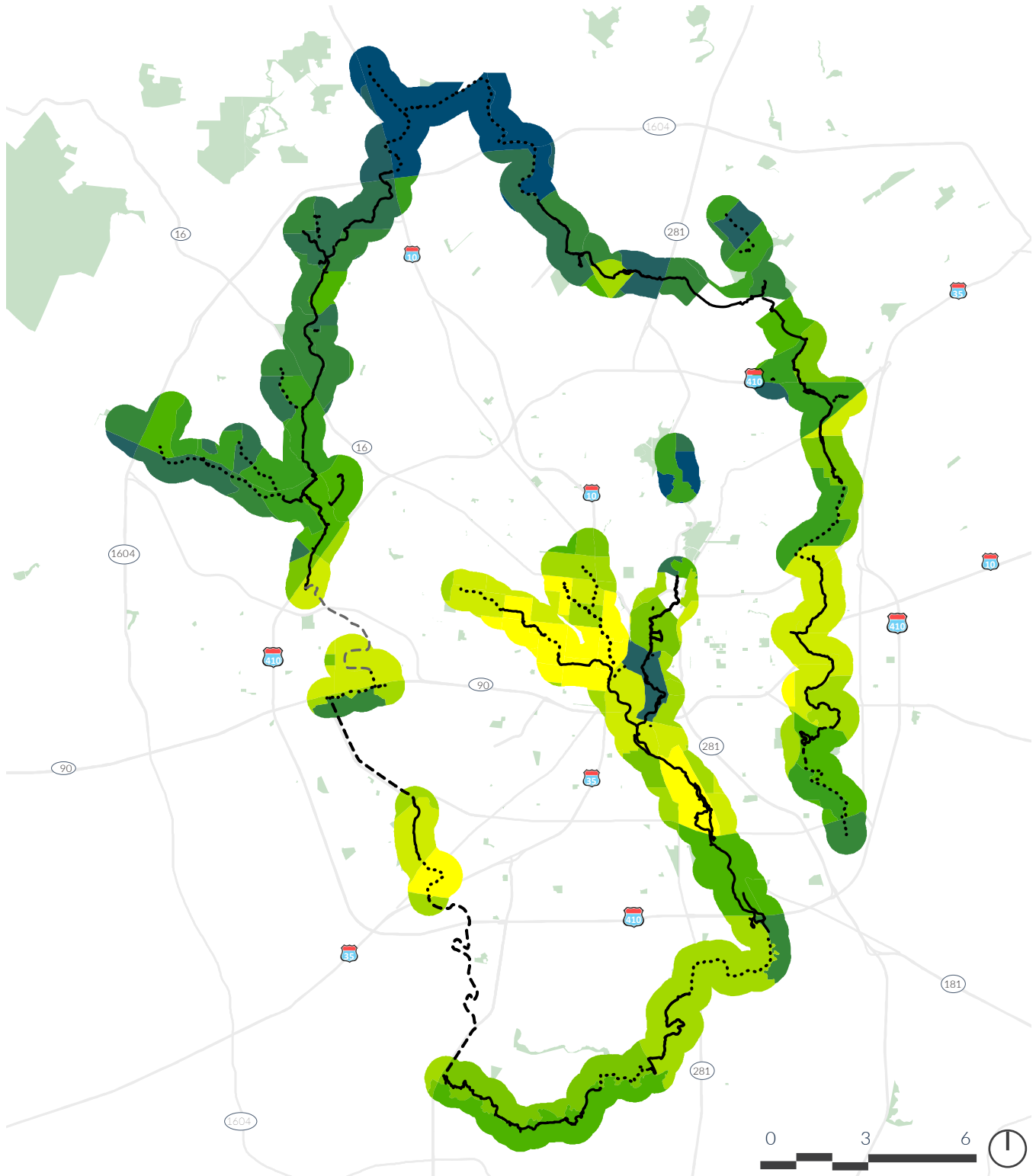

— Existing Trails	..... Potential Future Alignment	Medium Family Income
- - - Trails Under Construction/Design	○ 1 Mile Buffer	<div style="display: flex; align-items: center;"> <div style="width: 20px; height: 20px; background: linear-gradient(to top, yellow, green, blue); border: 1px solid black; margin-right: 5px;"></div> <div> <p>\$11,076</p> <p>\$236,750</p> </div> </div>
..... Approved Trails		

Source: ACS 2012-2016 5-year

# MEDIAN AGE NEAR TRAILS

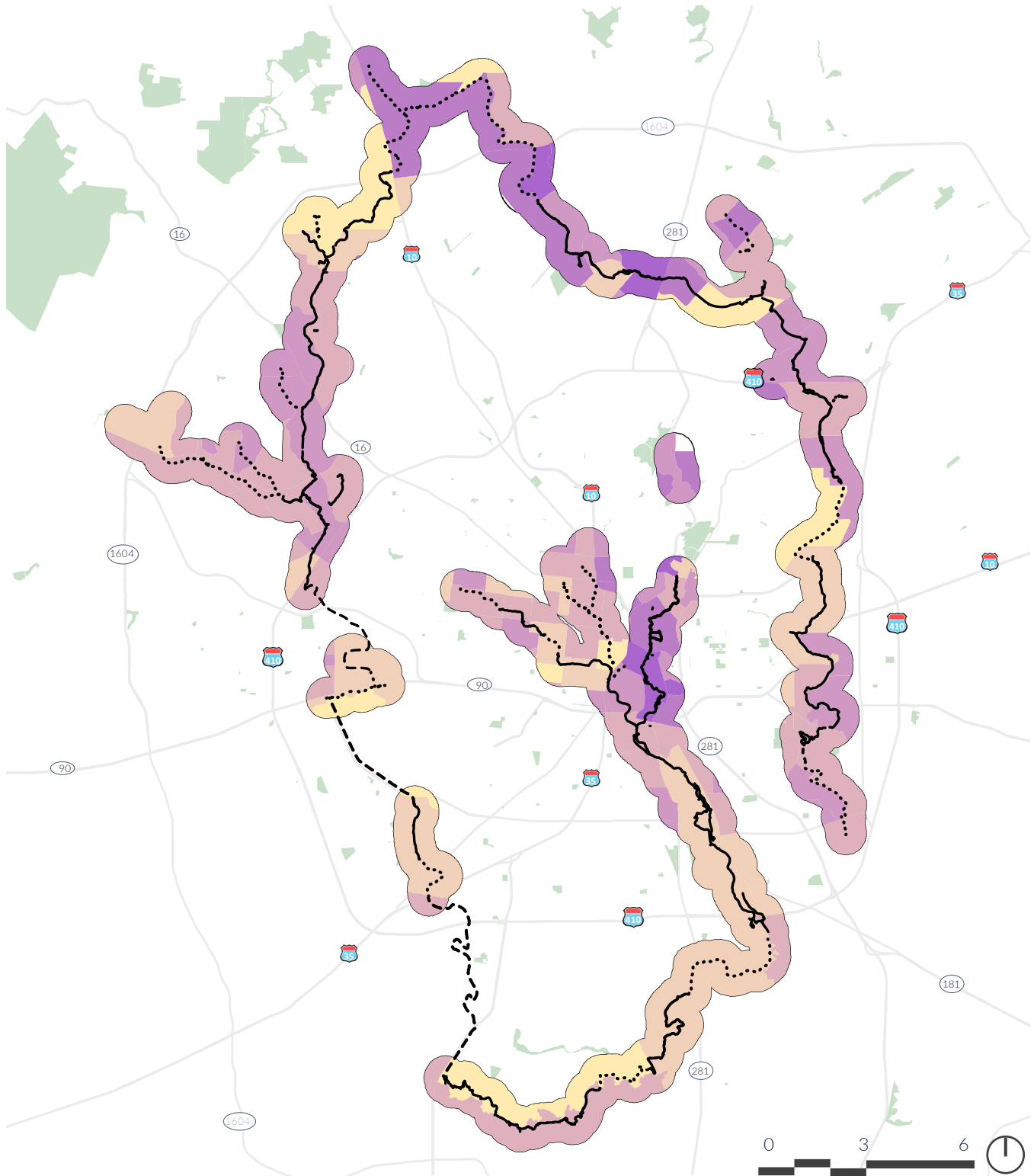

- Existing Trails
- ..... Trails Under Construction/Design and Approved Trails
- - - Potential Future Alignment

 1 Mile Buffer
 
 Median Age  
 21  
 50



Source: ACS 2012-2016 5-year



## RACIAL DISTRIBUTION NEAR TRAILS

### ECONOMIC SEGREGATION AND RACE

San Antonio is one of the most economically segregated cities in the country. It comes as no surprise then, that this translates to a certain level of racial segregation as well.

After Anglo settlers began outnumbering Hispanic residents of the City in the mid 19th century, the Hispanic population began concentrating on the west and south sides of the City, while the Anglos were concentrated in the central and North sides. These communities were divided by San Pedro Creek, which is today being restored but for much of the 20th century was channelized or covered by highway I10.

This dividing line was institutionalized through Jim Crow racial zoning, which restricted Hispanics to the west, and blacks to the east. Today, these dividing lines are still well delineated. While racial zoning and redlining have been technically outlawed, economic conditions for these communities have led to de-facto racial segregation.

## RACIAL DISTRIBUTION NEAR TRAILS

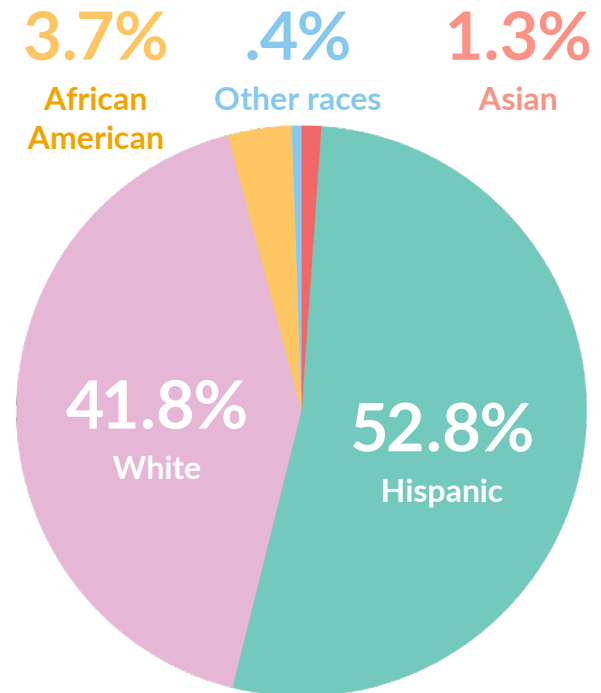

Source: ACS 2012-2016 5-year

### DESIGN RELEVANCE

The HWP Greenway addresses equitable access to active transportation and recreation while connecting communities and promoting community pride in a positive way. In future trail planning and improvement efforts, it is important to keep in mind the racial distribution throughout the City to address individual community needs through the lens of equity.

### HISPANIC POPULATION

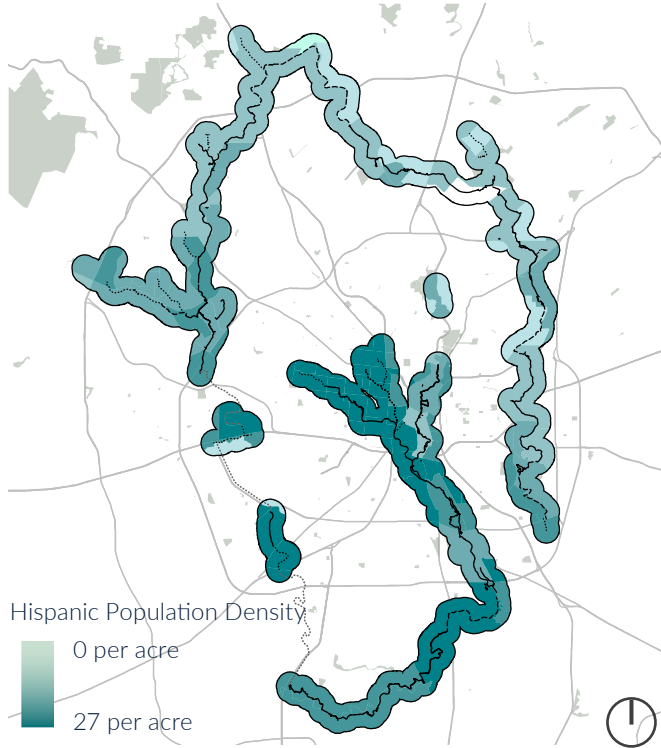

### BLACK POPULATION

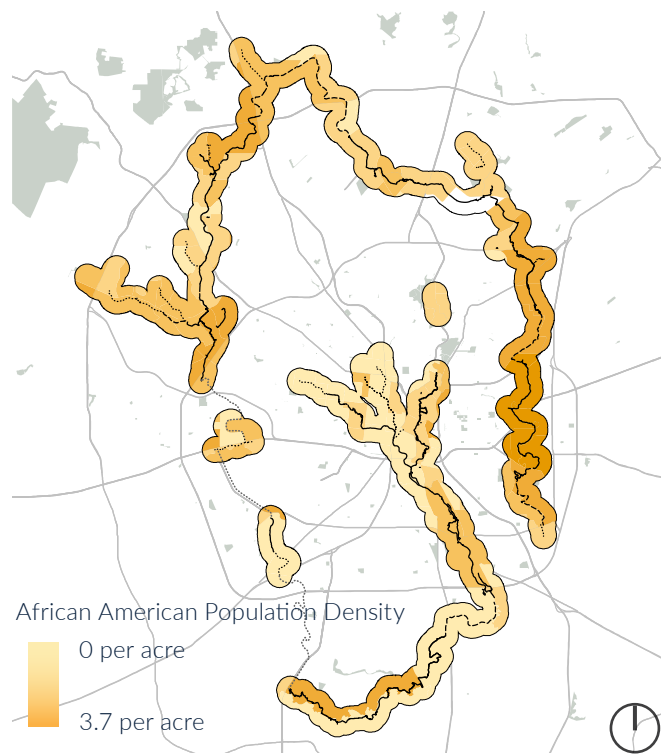

### WHITE POPULATION

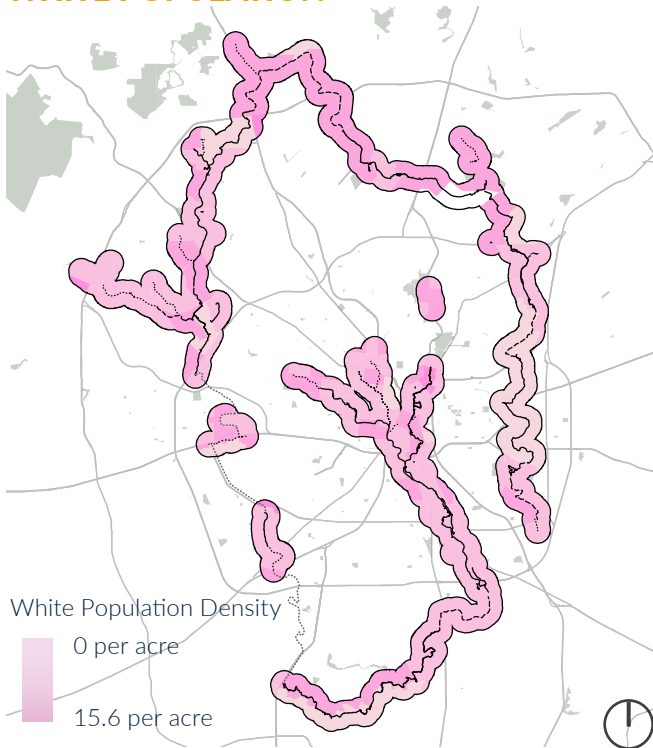

### ASIAN POPULATION

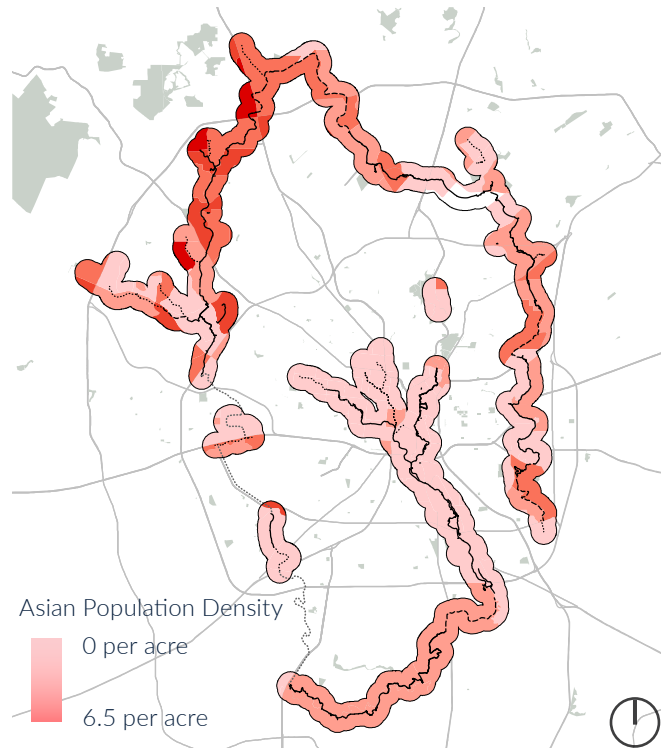

# 3.4 ENVIRONMENTAL CONTEXT

## BIOREGIONS

### EDWARDS PLATEAU

Extending over much of Central Texas, the Edwards Plateau contains vital watersheds and habitats that support the ecological and economic health of Texas. Historically, the land was characterized by sweeping Oak Savannas, which have been usurped by ash juniper thickets when the savannas were overgrazed by 19th century cattle.

The limestone geology create pristine aquifers, including the Edwards, which is among the most productive in the world. This reliable supply of water in an otherwise dry landscape has supported human settlement along the Balcones Escarpment for more than 10,000 years.

Key species - in terms of environmental importance- are:

**Key Plants:** Silver Bluestem, Turk’s Cap, Cedar Sage

**Key Trees:** Pecan, Cedar Elm, Texas Red Oak

### BLACKLAND PRAIRIE

Watered by numerous rivers and streams flowing from the Edwards Plateau, the Blackland Prairie is a rich grassland mosaic with fertile soils and a gently undulating landscape. The prairie extends southward from the central great plains where it meets its southern terminus around San Antonio.

Much like the Great Plains, the fertile soils of the Blackland Prairie have largely been converted into agricultural land, making it one of the most endangered bioregions in the country. The fragments that remain represent vital habitat and sequester as much, or possibly more carbon than forests of the same size.

**Key Plants:** American Beauty-Berry, Big Bluestem, Purple Coneflower

**Key Trees:** Sycamore, Burr Oak, Eastern Cottonwood

### SOUTH TEXAS BRUSH COUNTRY

From the southern border to central Texas, the South Texas Brush Country is among the most tropical bioregions in the United States. Like other bioregions that pass through San Antonio, the brush country has seen significant degradation from overgrazing. What was once rolling grasslands and subtropical woodlands is now thickets of mesquite and prickly pear cactus.

Despite this degradation, the brush country continues to be vital habit for rare species such as the Ocelot and the northern-most range of tropical species such as the Green Jay.

**Key Plants:** Texas Craglily, Heartleaf Hibiscus, Scarlet Sage

**Key Trees:** Hackberry, Brasil, Anaqua

### DESIGN RELEVANCE

The trail spans across three distinct bioregions. Each bioregion has distinct soils and climate, which will affect the tree and plant species selected for planting alongside the trail and in determining the most appropriate LID features.



# BIOREGIONS

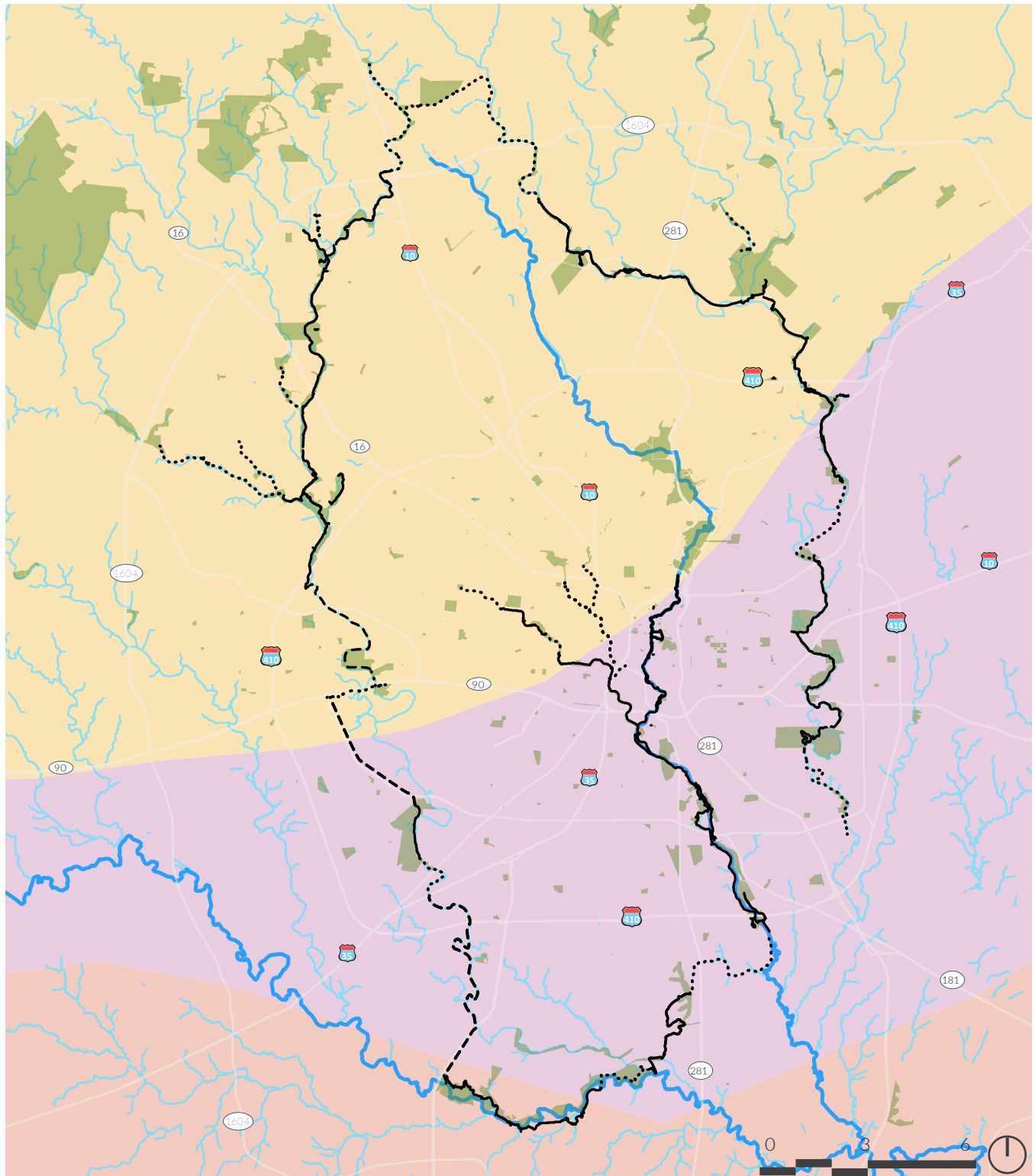

— Existing Trails	● Edwards Plateau	● Parks	Source: U.S. Environmental Protection Agency
..... Trails Under Construction/Design and Approved Trails	● Blackland Prairie		
- - - Potential Future Alignment	● South Texas Brush Country		

## TRAIL SEGMENTS IN FLOODPLAINS

### A CITY OF CREEKS

San Antonio's complex network of springs, creeks, and rivers provides linear greenways that are ideal recreation, active transportation, and wildlife corridors. The city's urban fabric is defined by its early development along the San Antonio River, however, frequent flooding lead to the channelization of most of the urban waterways in the 20th century. Today, there is opportunity to restore much of the ecological function of the waterways while improving flood control and installing urban trails.

The cross-cutting right-of-ways and often wooded conditions make the riparian zones of waterways appealing locations for trails, however frequent flooding also presents significant challenges for the trail's maintenance, accessibility, and safety. Additionally, major flood events are predicted to increase in the next century due to climate change, therefore all trails built in or even near 100 year floodplains will require design strategies such as Green Stormwater Infrastructure to mitigate the effects of frequent flooding.

### TRAILS IN FLOODPLAINS

Analysis of the entire trails network, (including major side trails, parallel trails, and trails currently only planned or under construction) shows that 240.8 miles of the 251.5 miles of network are inside of the 100 year floodplain. This challenge will only increase as flooding becomes more frequent.

### DESIGN RELEVANCE

Over 95% of the trail system is in the floodplain and must be constructed with frequent flooding in mind. Site elements, such as shade structures and benches, must be constructed to withstand occasional inundation.

# TRAIL SEGMENTS IN FLOODPLAINS

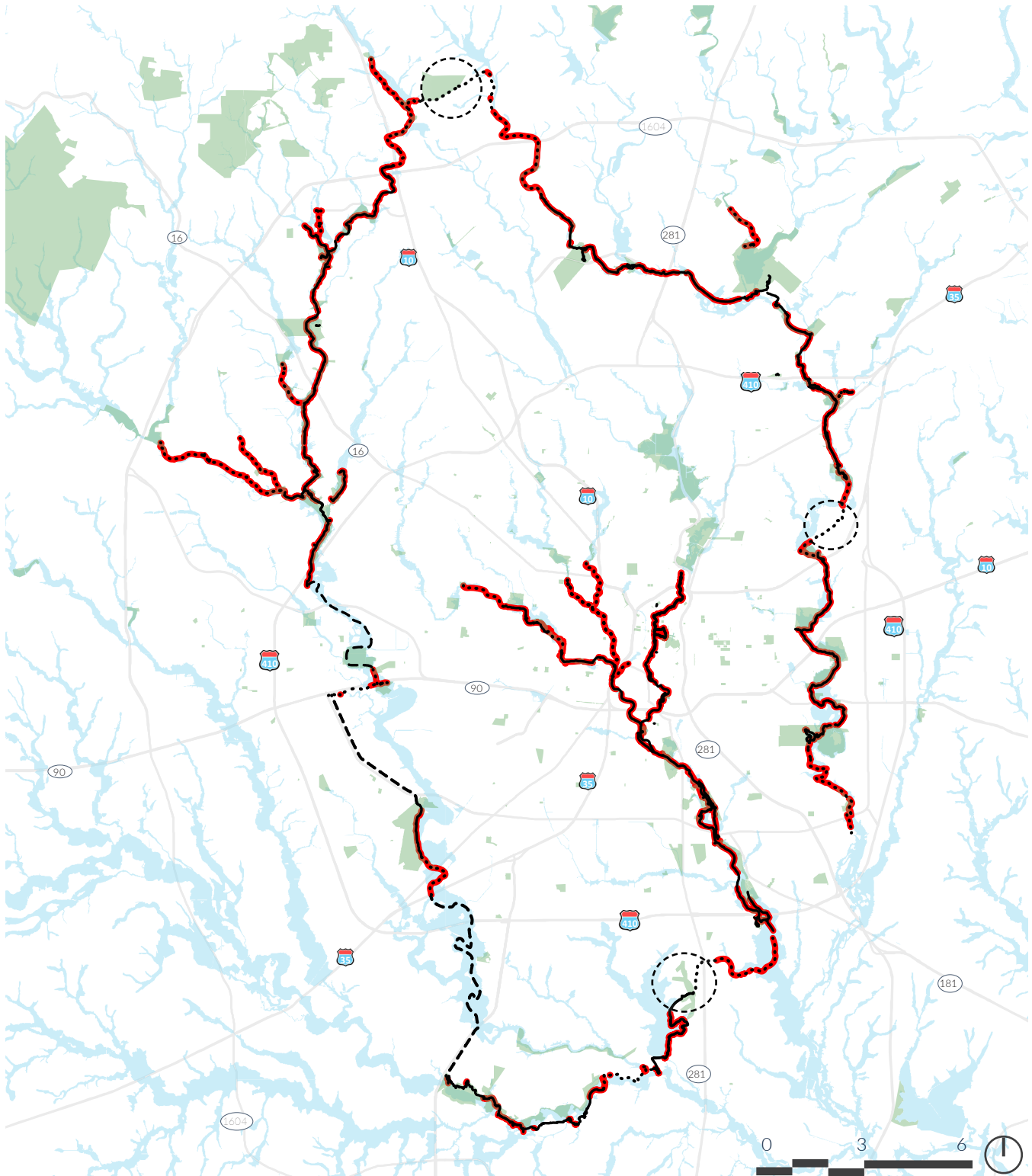

- Existing Trails
  - Trail in Floodplain
  - ⊙ Significant Areas Outside Floodplain
  - ⋯ Trails Under Construction/Design and Approved Trails
  - 100-year Floodplain
  - - - Potential Future Alignment
- Source: FEMA



## MOST COMMON SOILS NEAR TRAILS

### SOIL TYPES

According to the “NRCS Web Soil Survey,” Trail Suitability Ratings from the United States Department of Agriculture (USDA) Natural Resources Conservation Service (NRCS), are based on the soil properties that affect trafficability and erodability. These properties are stoniness, depth to a water table, ponding, flooding, slope and texture of the surface layer. Analysis shows that the following soil types are the most common within a mile buffer of the trail system.

### DESIGN RELEVANCE

Soil properties affect the erodability, trafficability, and texture of a trail and informs the way trails are constructed. Retaining wall selection, trail alignment, and structural footings, among others, should consider soil properties as a key part of determining the best design opportunity.

**TABLE: SOIL PROPERTIES**

	Lewisville Silty Clay	Eckrant Cobbly Clay	Sunev Clay Loam	Patrick Soils	Crawford and Bexar Stony
<b>Soil Taxonomy</b>	Loamy and clayey alluvium	Clayey-skeletal, smectitic, thermic Lithic Haplustolls	loamy alluvial sediments that are high in calcium carbonate	Clayey over sandy or sandy-skeletal, carbonatic, thermic Typic Calcustolls	Fine, smectitic, thermic Leptic Udic Haplusterts
<b>Drainage</b>	Well drained, moderate permeation	Well drained, moderately slow permeation	Well drained, moderate permeation	Well drained, moderate permeation	Well drained
<b>Typical Landscape</b>	River Valleys	Dissected plateaus	Dissected and undulating plateaus	Dissected plains and River Valleys	Plains

# MOST COMMON SOILS NEAR TRAILS

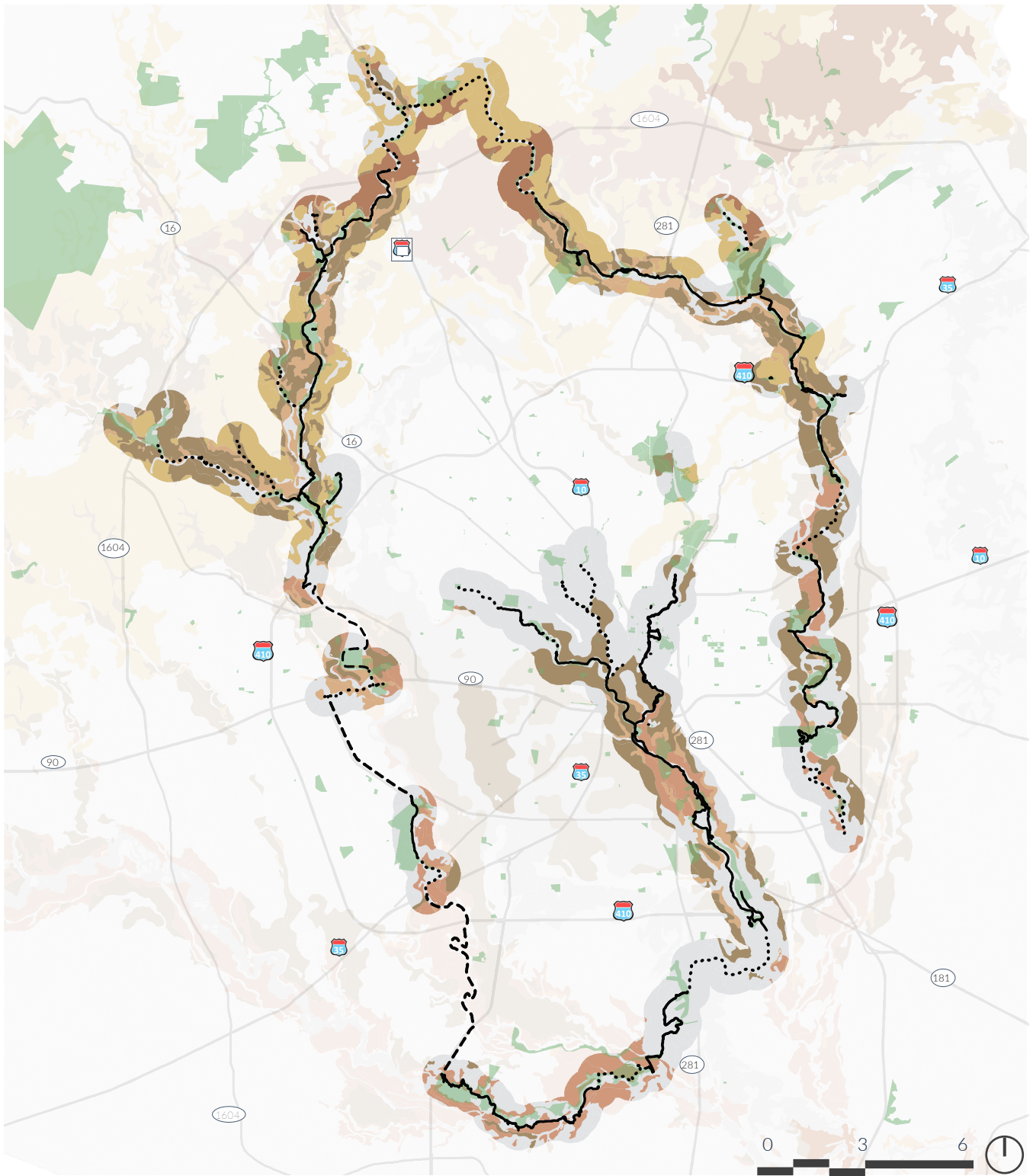

- Existing Trails
- ..... Trails Under Construction/ Design and Approved Trails
- - - Potential Future Alignment
- Lewisville Silty Clay
- Eckrant Cobbly Clay
- Sunev Clay Loam
- Patrick Soils
- Crawford and Bexar Stony

Source: NRCS Soil Survey

## TREE CANOPY ADJACENT TO GREENWAY TRAILS

Tree canopy throughout the HWP Greenway System could generally be improved. The map to the right highlights key locations where tree canopy is lacking. The potential success of reforestation along the Greenway hinges on the selection of the appropriate plants for the bioregion, as well as an understanding of how different bioregions vary in their ability to sustain canopy.

### DESIGN RELEVANCE

Tree canopy over a trail helps cool the trail and provides trail users with shade and respite from heat. Assessing the tree canopy adjacent to the trails helps prioritize location of future tree plantings. Additionally, the shade structures recommended in this document can be located in areas identified with low tree canopy.



# TREE CANOPY ADJACENT TO GREENWAY TRAILS

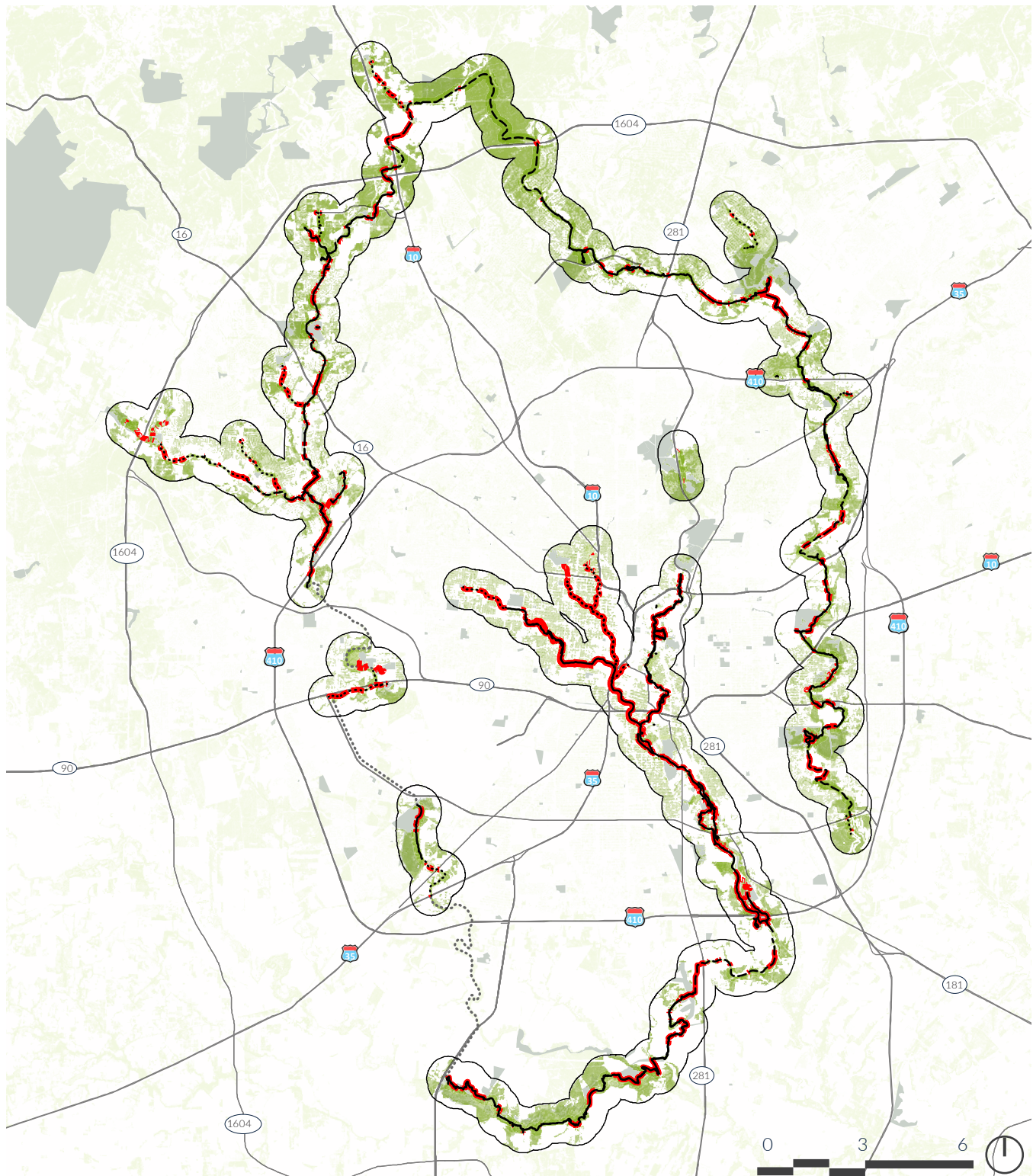

- Existing Trails
- ..... Trails Under Construction/Design and Approved Trails
- - - Potential Future Alignment

- Trail Segments with No Canopy Cover
- 1 Mile Buffer

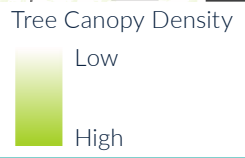

Source: National Forest Service, National Land Cover Database

# 3.5 LAND USE AND TRANSPORTATION

## LAND USE THEMES

The central core of the city is characterized by dense mixed-use development where the urban form is respondent to layers of colonial history, frequent flooding and a gilded age economic boom.

Following WWII, San Antonio followed much of the country in the rapid adoption of the automobile and thus began developing outward from its urban core. Military bases were established or expanded on the City’s outer edges, while major economic centers such as the Medical Center and UTSA were established on the City’s far Northside. In the early 2000’s, major investment in the City’s southside such as the establishment of the Toyota manufacturing plant and Texas A&M San Antonio have begun to direct more development southward.

This pattern of development has made San Antonio a prototypical Sunbelt American City, where a central business district with little housing is surrounded by sprawling housing developments, interspersed with nodes of commercial developments or subsumed suburbs that each have their own individual character.

### DESIGN RELEVANCE

Differing land uses defines San Antonio neighborhoods, creating distinct urban, suburban, and rural environments. These land uses informed the creation of “Character Areas” along the HWP Greenway. The various Character Areas have distinct site furnishings that reflect the personality of the Character Area.

CURRENT LAND USE SHARE NEAR TRAILS\*

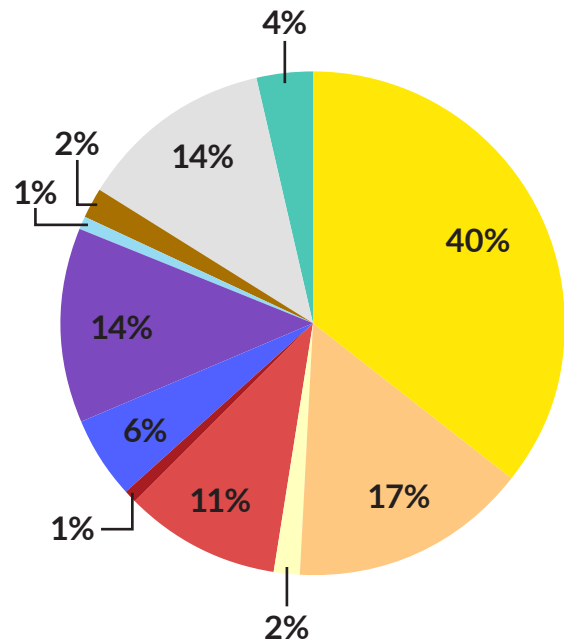

- Single Family
- Multifamily
- Mixed-Use
- Commercial
- Downtown
- Office
- No Classification
- Education
- Military
- Outside City Limits/ROW
- Conservation
- Park

\*Data used in the above statistics and “Current Land Use Near Trails” Map to the right is based on the most up-to-date data from the City of San Antonio Planning Department as of August 2018. Some recent and/or new land use may not be reflected in this analysis.

# CURRENT LAND USE NEAR TRAILS\*

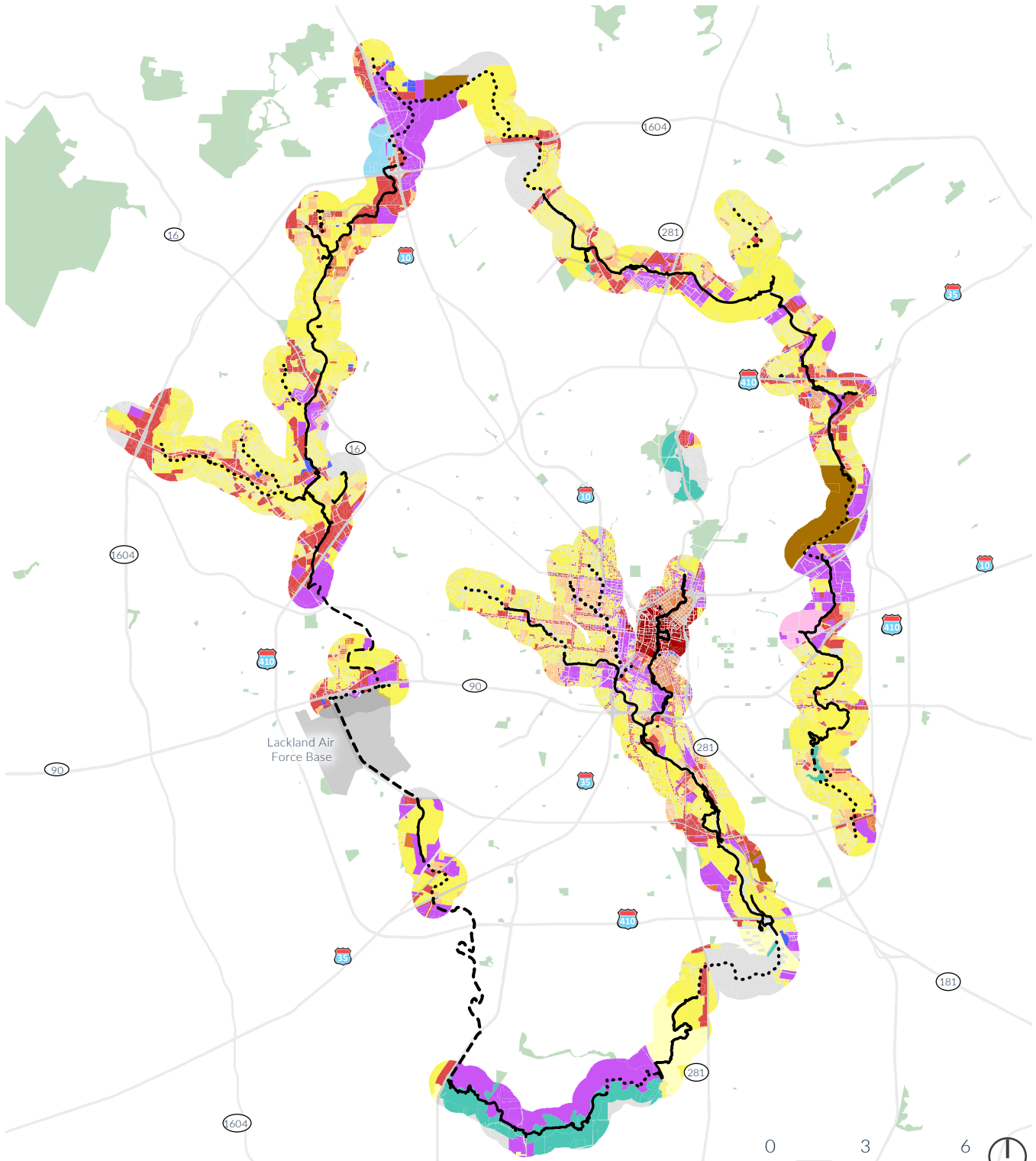

- Single Family
- Commercial
- No Classification
- Outside City Limits/ROW
- Multifamily
- Downtown
- Education
- Conservation
- Mixed-Use
- Office
- Military
- Park

Source: City of San Antonio



## TRANSPORTATION THEMES

The City's transportation infrastructure both reflects and directs the City's development patterns. Despite once having a world-class streetcar system, the City is today almost entirely dependent on automobile transportation. One's geography in the City is often described in relation to the two loop roads, 410 and 1604, that circumnavigate the City's historic boundaries. Three major highways bring traffic in and out of the central core: I10, I35, and 281, while numerous surface arterials manage local traffic, such as Fredericksburg Road. These highways have largely replaced the City's waterways as the major geographic, economic and cultural delineation lines, however many are based on a waterway's original course.

Faced with unprecedented growth, the City is ramping up efforts to expand its multi-modal transportation system. Since 2011, the City has adopted a comprehensive plan, a bicycle master plan, the VIA Transit master plan, and a regional transportation master plan. These efforts have coordinated to identify multi-modal transportation corridors and areas of future growth, where additional public transit and other infrastructure will be concentrated.

Randolph Park & Ride



Ingram Transit Center



Centro Plaza Transit Center, VIA Metro Transit



VIA Kel-Lac Transit Center



## DESIGN RELEVANCE

The HWP Greenway system is expected to play an increasingly prominent role in the City's transportation network over the coming decades. Knowledge of existing transit hubs and public transportation routes will help inform key connections the trail can make between city amenities, homes, and places of work.



# TRANSIT NEAR TRAILS

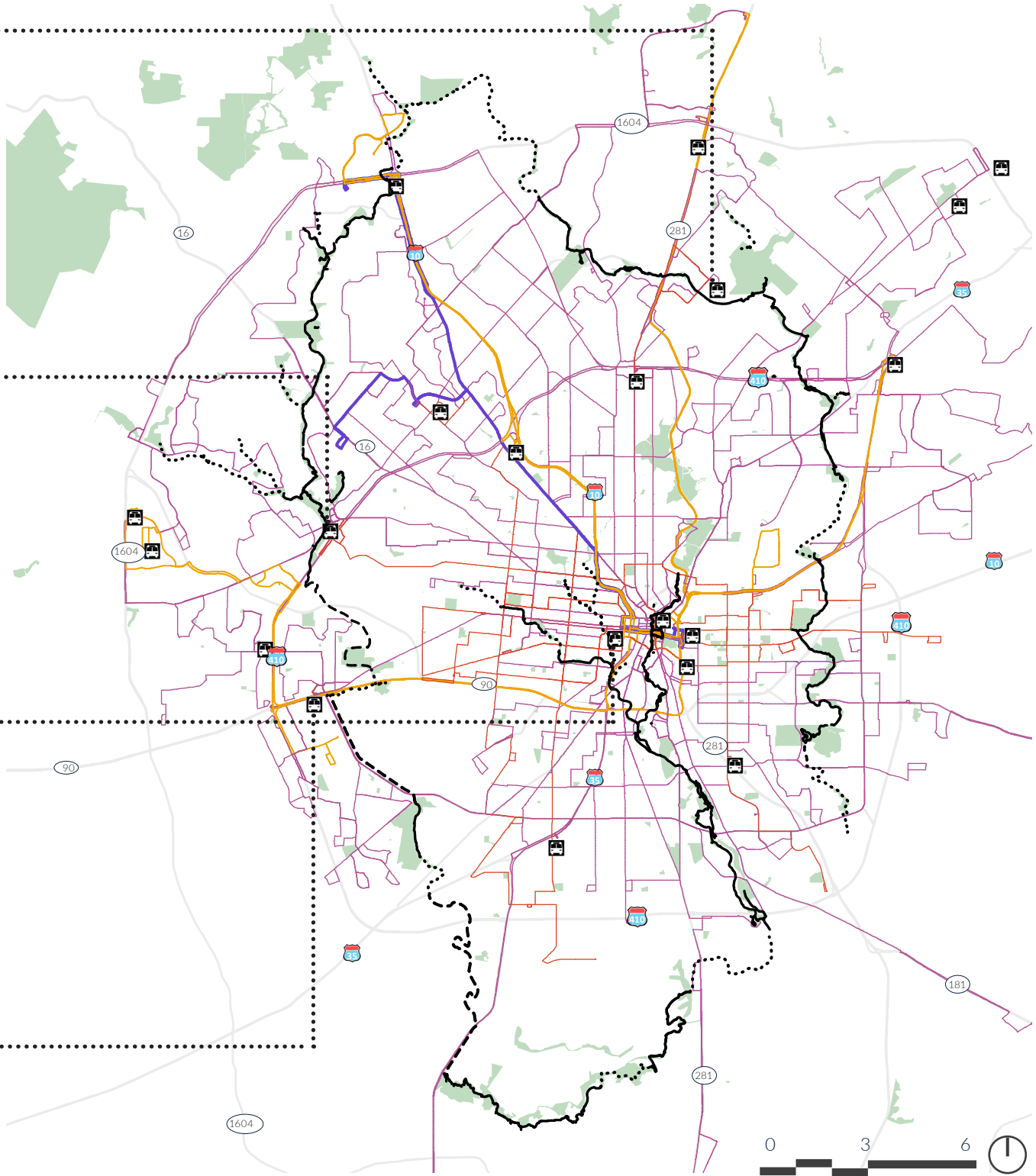

- Existing Trails
- ..... Trails Under Construction/Design and Approved Trails
- - - Potential Future Alignment
- Frequent
- Express
- Metro

 Major Transit Hub



Source: VIA Metropolitan Transit

# 3.6 TRAIL USE FREQUENCY

## USE NUMBERS

The HWP Greenway System sees wide variations in use demand, as evidenced by anecdotal observations by trail managers and strategically installed “eco-counters” which quantify trail use using sensor technology. Using this data, it is clear that the Leon Creek North segment is by far the most heavily trafficked area in the project scope, followed by Salado North and the West Side Creeks, while the Medina and Salado South segments only garner a small fraction of the traffic on Leon Creek.

This is a function of a variety of factors. The Leon Creek segment is likely so successful due to its relatively high population density and connectivity between major commercial and recreational hubs. Meanwhile, segments such as Medina are isolated from residential areas, and have not yet been connected to other, more highly trafficked segments.

For segments such as Salado South, the relatively low trail use seems to be at odds with its positioning in a relatively high population area and connection to major hubs such as the AT&T Center. This can likely be explained through other factors such as low connectivity and awareness to adjacent neighborhoods and lack of connection to the Salado North segments. Once this connection is establishment, trail demand could very well increase, and thus planning for such a future will require further analysis for future Trail Capacity.

## DESIGN RELEVANCE

Trail use analysis helps inform the types of construction that occurs along the trail. Trails with a high frequency of use will need to be wider (see section on Trail Capacity on page 43) and may need more site furniture amenities to accommodate more users.

# DAILY USERS MAP

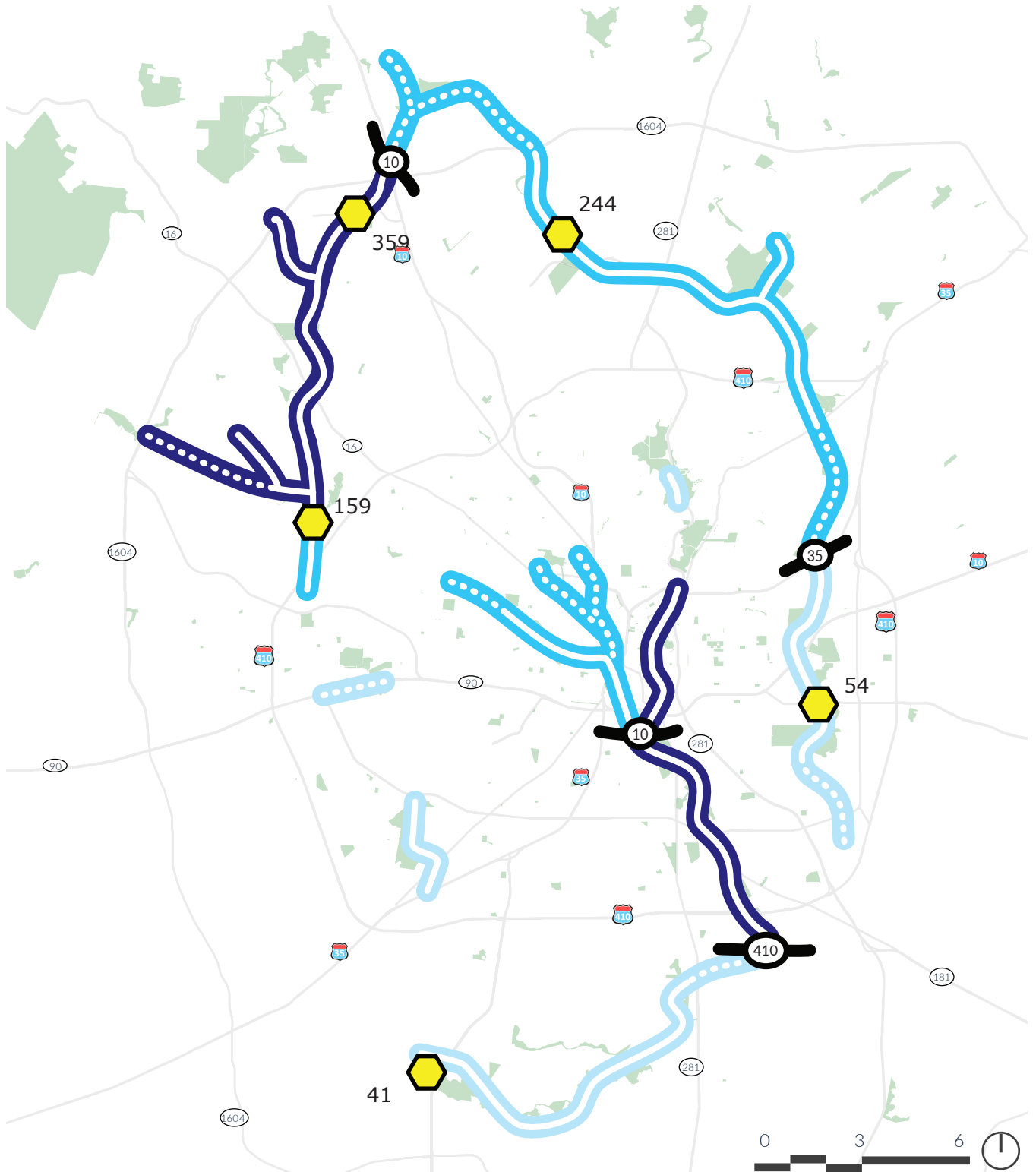

Existing Trails  
Planned Trails

Low Use  
Medium Use  
High Use

Trail Counter with Avg. Daily Trail Use\*  
\*February 2017-March 2018 Monthly Average



# 3.7 TRAIL CAPACITY

## LOCALIZING TRAIL DESIGN

Trail Capacity is a term adapted from the Federal Highway Administration’s “Level of Service” measurement, which is a qualitative measure used to relate the quality of traffic flow and number of users easily accommodated. Trail Capacity is an adaptation of Level of Service intended to provide a measurement of trail service capabilities and operational conditions. To determine trail capacity, population density within a half-mile of trails and frequency of trail usage were combined. The following categories were established using the above methodology:

- **Trail Capacity A:** Segments of the trail with the highest capacity needs based on surrounding populations density and estimate of trail use frequency.

- **Trail Capacity B:** Segments of the trail with intermediate capacity needs based on surrounding populations density and estimate of trail use frequency.
- **Trail Capacity C:** Segments of the trail with the lowest capacity needs based on surrounding populations density and estimate of trail use frequency.

### DESIGN RELEVANCE

Trail Capacity informs the width of the trail - high capacity trails need to accommodate more people and will be wider, while low capacity trails see less use and can be narrower. Trail capacity also informs the trailhead recommendations and the furnishings located at the trailhead.

POPULATION DENSITY



TRAIL CAPACITY

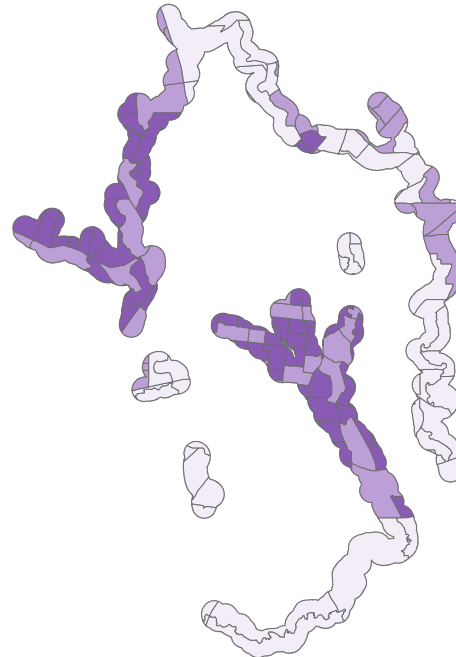

TRAIL USE FREQUENCY



# TRAIL CAPACITY THROUGHOUT TRAIL NETWORK

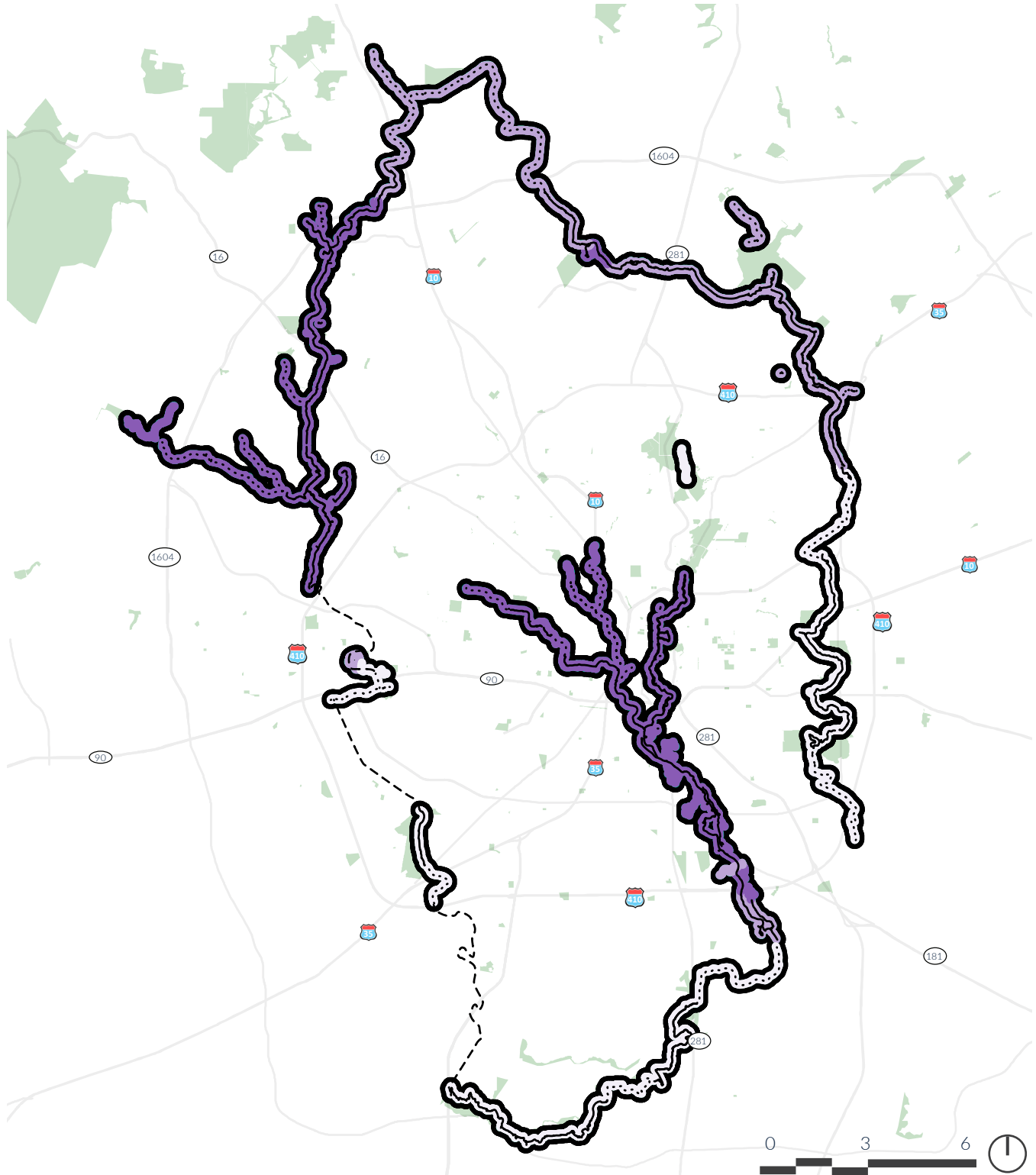

- Trail Capacity A
- Trail Capacity B
- Trail Capacity C
- Existing Trails
- Trails Under Construction/Design and Approved Trails
- Potential Future Alignment

# 4 TRAIL DESIGN VISION

Using the above site analysis and engagement with City stakeholders, the consultant team and City trail managers developed the following framework with which to unify future trail development under a common vision.

The framework breaks the system into six unique “Character Areas” which each will have unique aesthetic characteristics while also maintaining uniform quality standards and connectivity. Trail design specifications will be applied depending on the segment’s intended “Trail Capacity,” which was determined using an aggregate of factors including population density and frequency of trail usage. Finally, specific trail needs such as shade or flood infrastructure will be addressed using components specified in the system “Toolkit.” The toolkit will allow trail managers to uniformly install appropriate trail amenities and infrastructure and eliminate the need to individually design solutions across the trail system.



# 4.1 THE VISION

## HWP GREENWAY PROGRAM GOALS

The program goals of the greenway system are core to the vision of the Trail Design Strategy. The goals are as follows:

- Access to outdoor recreation
- Pedestrian and bicycle mobility
- Park system connectivity
- Open space and habitat conservation

## TRAIL DESIGN STRATEGY OBJECTIVES

The Trail Design Strategy establishes design principles, criteria for application, and enhanced features; which combine city-wide branded elements, with other features entitled to reflect the unique character of the neighborhoods in which they will be placed.

- To provide an administrative vehicle to channel and harmonize current and upcoming design initiatives for the best possible impact on their surroundings and aligning them in a consistent way.
- To raise the quality of trails and make of this -already loved- infrastructure an even more valued city asset by residents, and eventually become an icon of San Antonio for visitors as well.
- To spark neighborhood revitalization, as a key component of urban regeneration, acting as a catalyst for infill redevelopment or neighborhood improvement in declining areas.
- To strategically apply Low Impact Development (LID) principles in an educational way, to showcase exemplary samples of best practices on water preservation and ecological design, for residents of all ages to enjoy and to get ideas from.

- To create a bolder city-wide vision for the entire Trail System, by thinking globally first, and acting locally then, in a coherent and consistent way, so each action/location speaks of the system and vice-versa.

## OTHER CONSIDERATIONS

The heart of the San Antonio trail system is the trail itself. Currently, newly constructed trail segments are made of 10' wide concrete. In the past, the City has experimented with other materials, such as asphalt, with various degrees of success. The linear trails team has expressed a desire to continue using concrete trails due to the ease of maintenance and overall cost effectiveness.

The linear parks team and stakeholders indicated challenges that must be considered as the trail system continues to develop:

1. The popularity of the trail system is growing every year and is attracting different types of user groups.
2. Historically, the trail had been primarily used by cyclists. In the past few years there has been an increase in the variety of users, including leisure walkers, tourists, long distance runners, families out for a weekend outing, and parents with strollers.
3. There are concerns about trail congestion and conflict between user groups (i.e. runners and cyclists).

## A TRANSECT METHODOLOGY

Transects were initiated as an effective tool for planners by many historic leaders in the planning and design professions including Patrick Geddes, Ian McHarg, and more recently, Andres Duany. Transects continue to be used by planners to describe changing conditions across a geographic area in a linear diagram. The Congress for New Urbanism (founded by Andres Duany), for instance, developed an influential transect that describes the changing conditions from wilderness to dense urban environments by breaking down the gradient



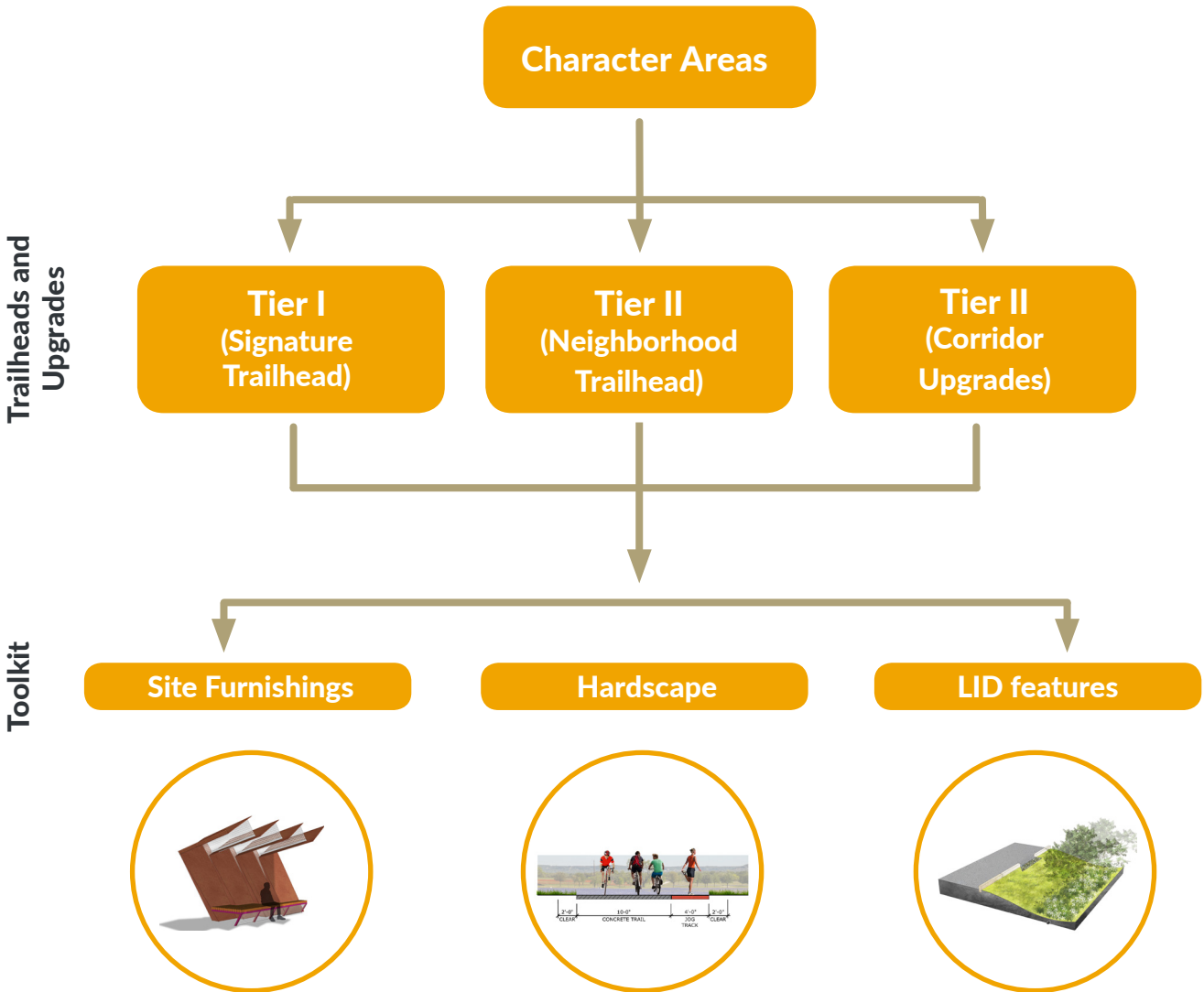
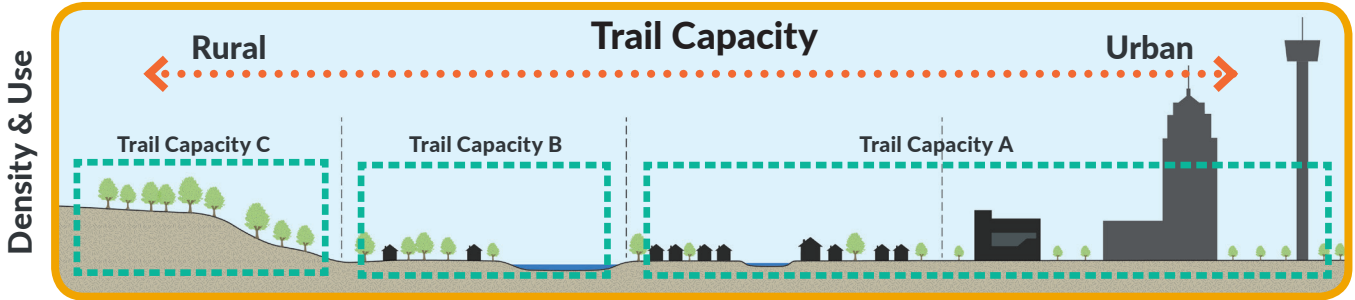

into distinct categories. While these categories tend to simplify otherwise complex urban fabrics, they make large scale planning much more feasible.









To address the disparate contexts of individual segments of the HWP Greenway system, the consultant team and City trail managers have used the transect methodology to break down the trail system into three distinct categories, each with a corresponding “Trail Capacity”; as well as to ascribe families of furnishings to specific Character Areas within certain Transect categories. The categories, described in detail below, are respondent to the varying degree of urban density, current frequency of use, and the role of each Transect Zone in the overall urban fabric of the City of San Antonio.

## CHARACTER AREAS

Character Areas are unique areas with both linear and spatial components across the trail system. Each Character Area was identified because of a variety of factors including its surrounding urban form, density, and use - i.e. its Transect Zone; the unique bioregion and corresponding landscapes each segment is within; and, carefully considered cultural and demographic differences across the region.

Each aspect of the system-scale site analysis identifies differences in each Character Area. Understanding those differences is vital in establishing a community identity on the HWP Greenway that gives residents a sense of pride and ownership for nearby trails. A community should always be given the opportunity to provide input on how they would like their trail system built and which amenities are most desirable. Community input meetings are a good way to gather such input.

## CHARACTER AREA MAP

-  Trail Complete
-  Trail Planned
-  Medina River
-  Salado Creek South
-  Salado Creek North
-  Leon Creek South
-  Leon Creek North
-  West Side Creeks
-  Mission and Museum Reach

The system is broken down into the following Character Areas:

- **Medina River**
- **Salado Creek South**
- **Salado Creek North**
- **Leon Creek South**
- **Leon Creek North**
- **Westside Creeks**

The following section outlines the unique characteristics of each Character Area in further detail than the previous Site Analysis. Both sections have informed the development and recommended application of the Design Toolkits (page 66)

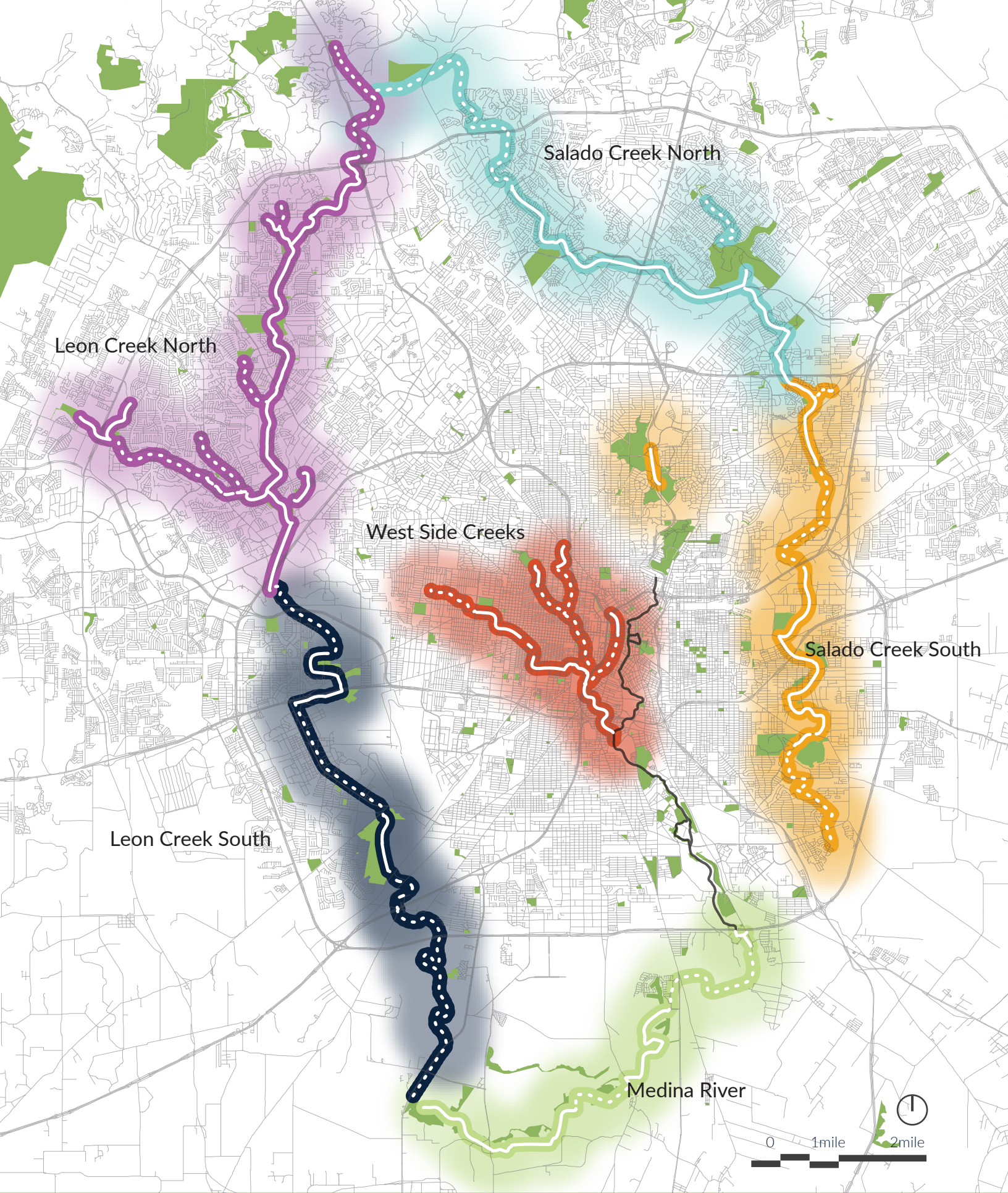



## 4.2 MEDINA RIVER

Situated far to the south of the City center, the Medina River trail is by far the most rural Character Area. With little urban development in the area, there is very little impervious cover, however an unexpectedly high portion of the trail is not covered by tree canopy. The low population density mean this segment is almost exclusively a recreational destination, however demand will likely rise significantly if and when the trail is connected to the popular Mission Reach Trail.

### PEOPLE

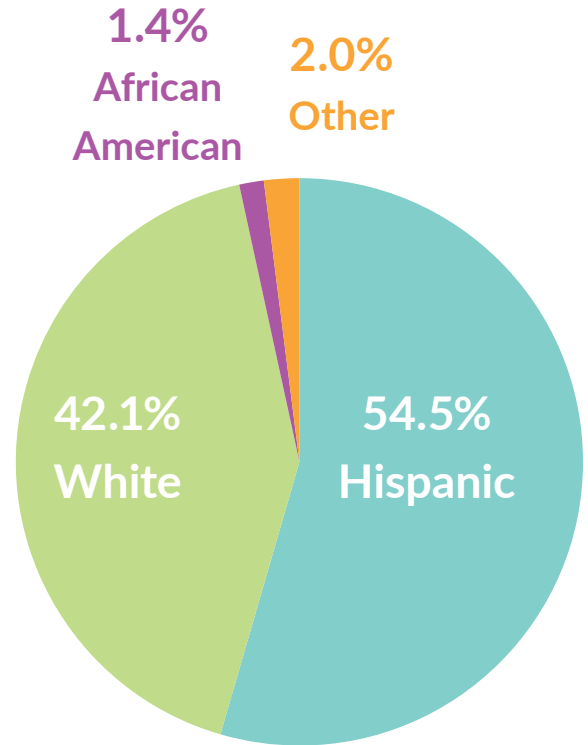



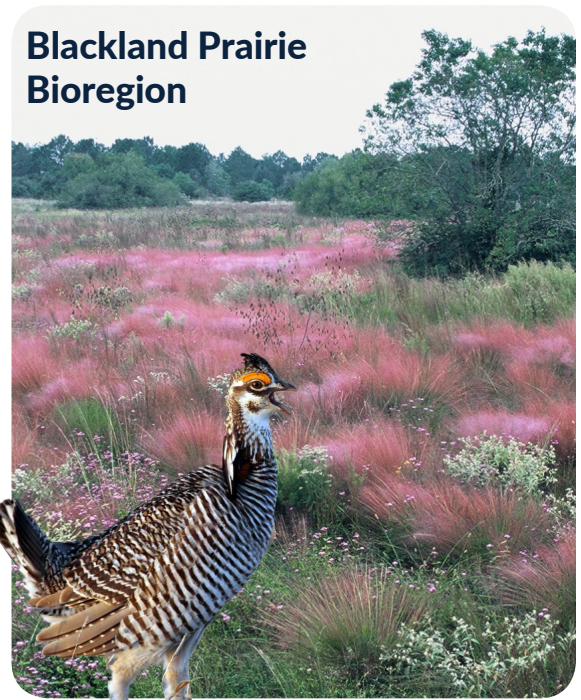
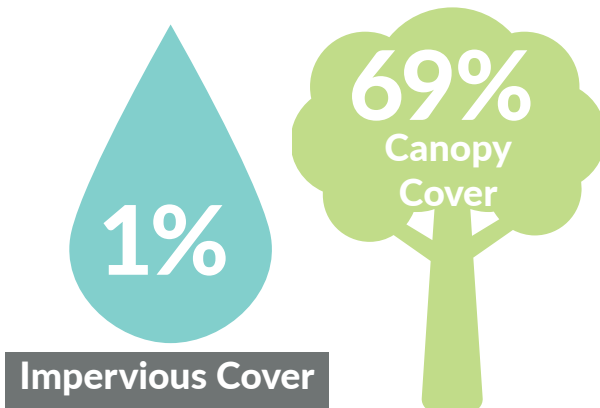





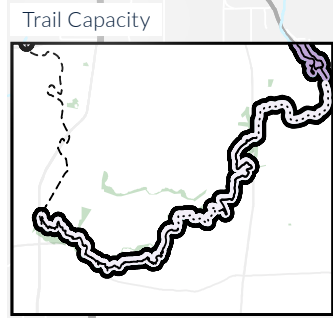
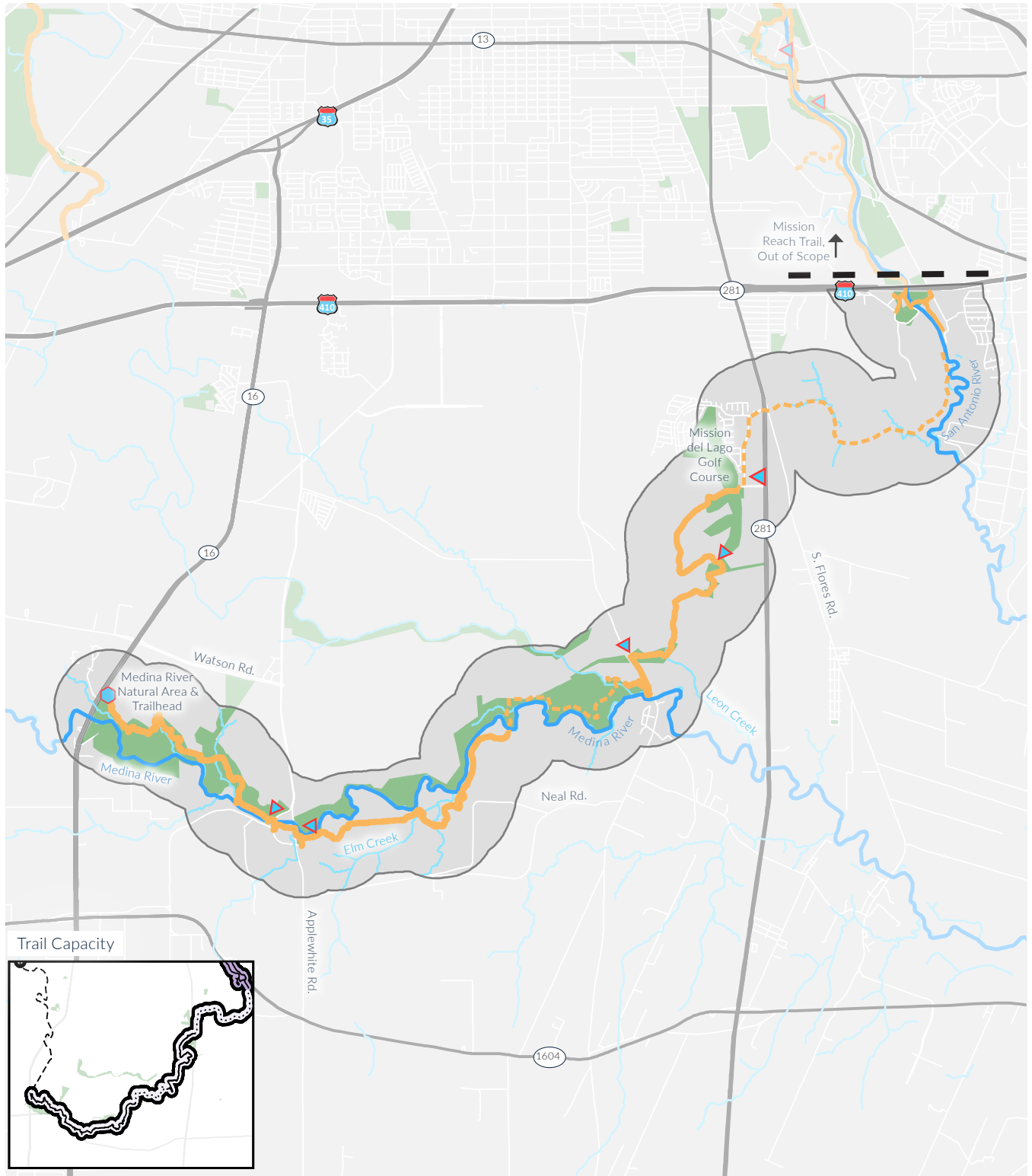

### ENVIRONMENT





# MEDINA RIVER



- |  |  |   |   |
|--|--|---|---|
|  Trail Capacity A |  Trail Complete       |  Tier 2 Opportunities |  |
|  Trail Capacity B |  Trail Planned        |  1 Mile Buffer        |   |
|  Trail Capacity C |  Tier 1 Opportunities |                      |   |

# 4.3 SALADO CREEK SOUTH

The Salado Creek South Character Area is currently disconnected from the north segment, leading to its relatively low use despite its urban setting. The trail is characterized by a highly forested setting and a natural creek beds. It connects users to Southside Lions Park, as well as the AT&T Center, home of the Spurs basketball team. There are significant opportunities to improve neighborhood connections and restore riparian function in this Character Area.

PEOPLE

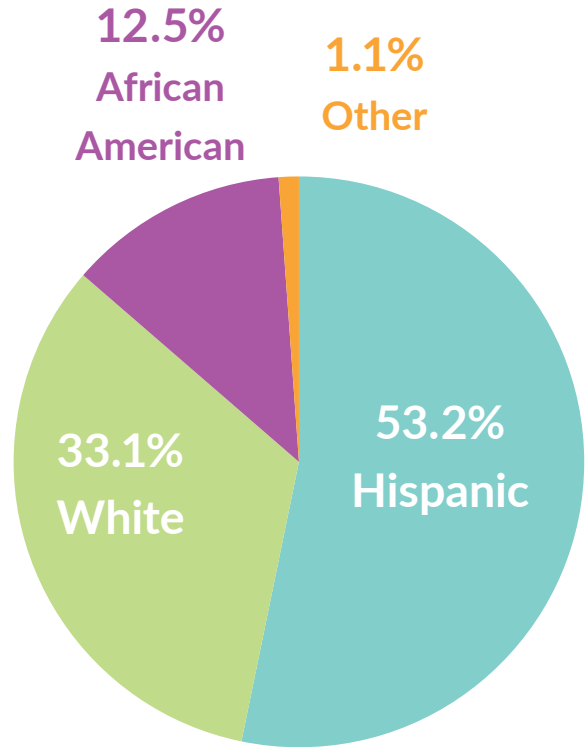

ENVIRONMENT

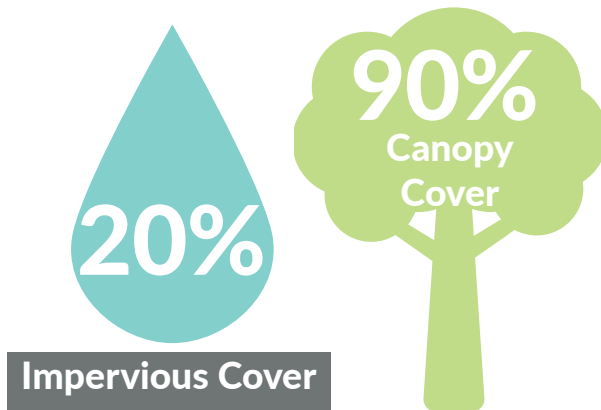

# SALADO CREEK SOUTH

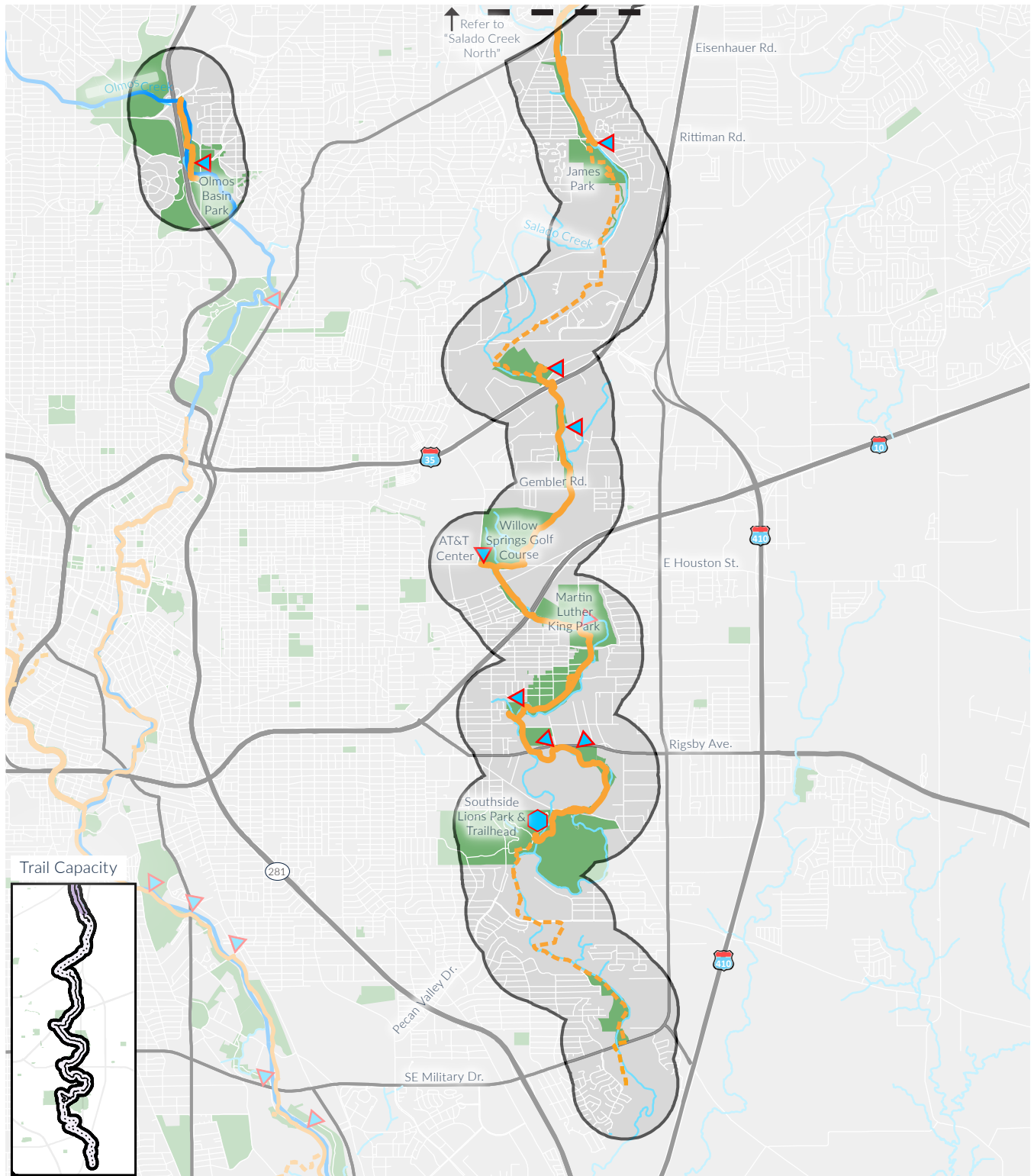

	Trail Capacity A		Trail Complete		Tier 2 Opportunities
	Trail Capacity B		Trail Planned		1 Mile Buffer
	Trail Capacity C		Tier 1 Opportunities		

# 4.4 SALADO CREEK NORTH

The Salado Creek North Character Area includes the system's most northerly segment, and follows the Salado Creek south through mostly low density suburban neighborhoods, interspersed with areas of high density mixed-use activity. The trail passes through a number of historic homestead sites, and connects regional destination parks such as Eisenhower, Phil Hardberger, and McAllister Parks. It is highly forested, but includes a number of major road crossings.

PEOPLE

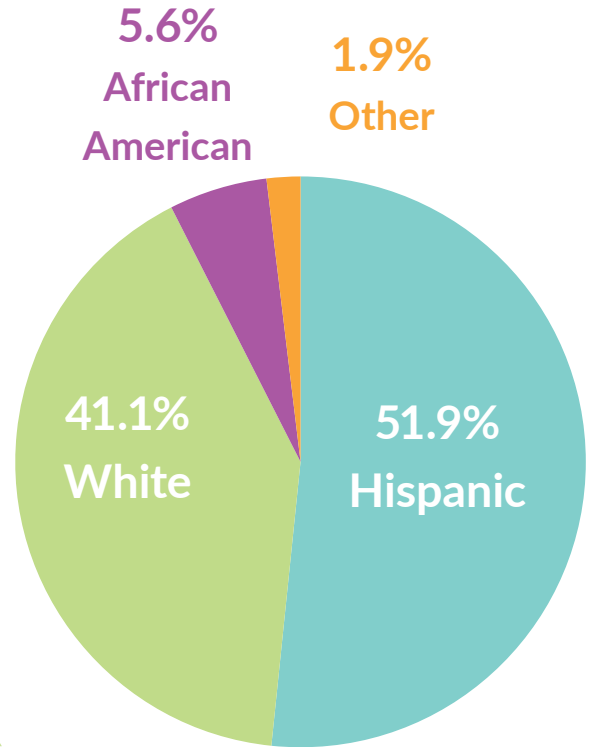

ENVIRONMENT

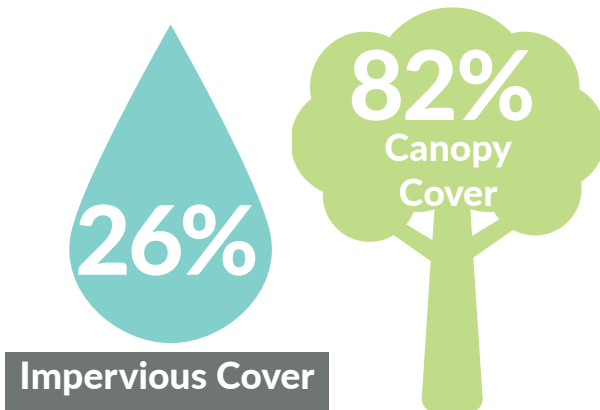



# SALADO CREEK NORTH

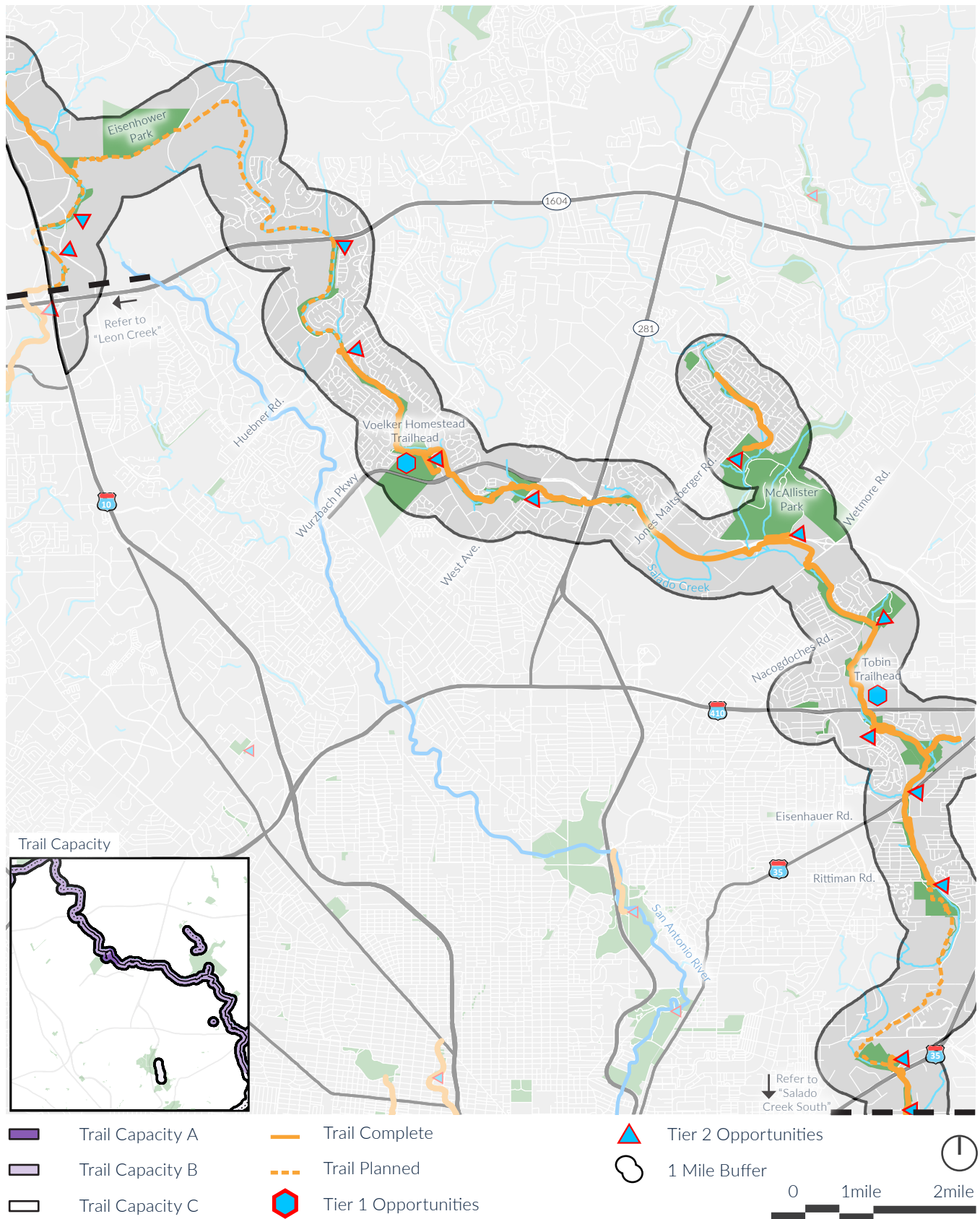

# 4.5 LEON CREEK SOUTH

The Leon Creek South Character Area is the least developed to date and will require substantial investment in both solidifying trail alignment, working with stakeholders to ensure buy-in, and securing the land necessary to construct new segments. There is substantial growth pressure in SW San Antonio and Leon Creek South is uniquely situated to pre-emptively accommodate the areas new residents for years to come. The adjacency to Lackland Air Force Base certainly should be considered as both an asset and a location of key stakeholders.

PEOPLE

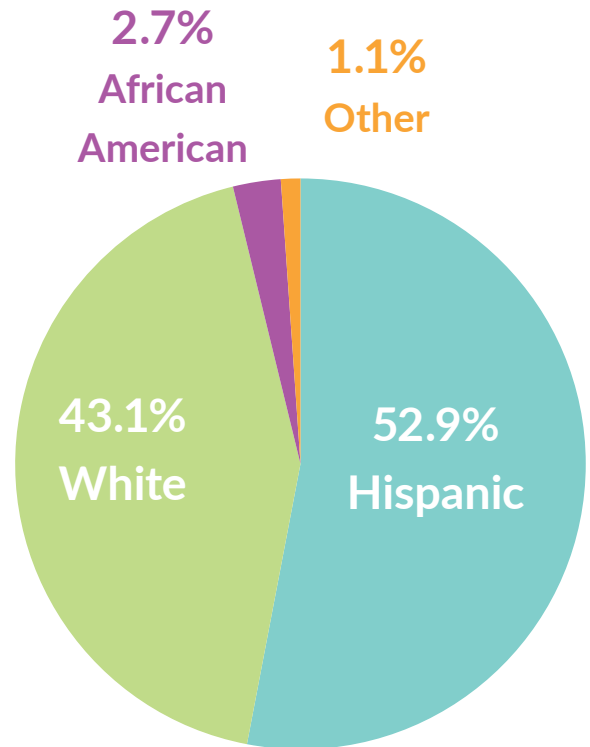

ENVIRONMENT

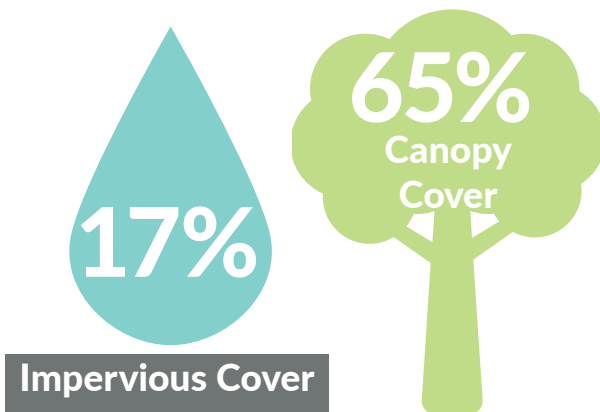

# LEON CREEK SOUTH

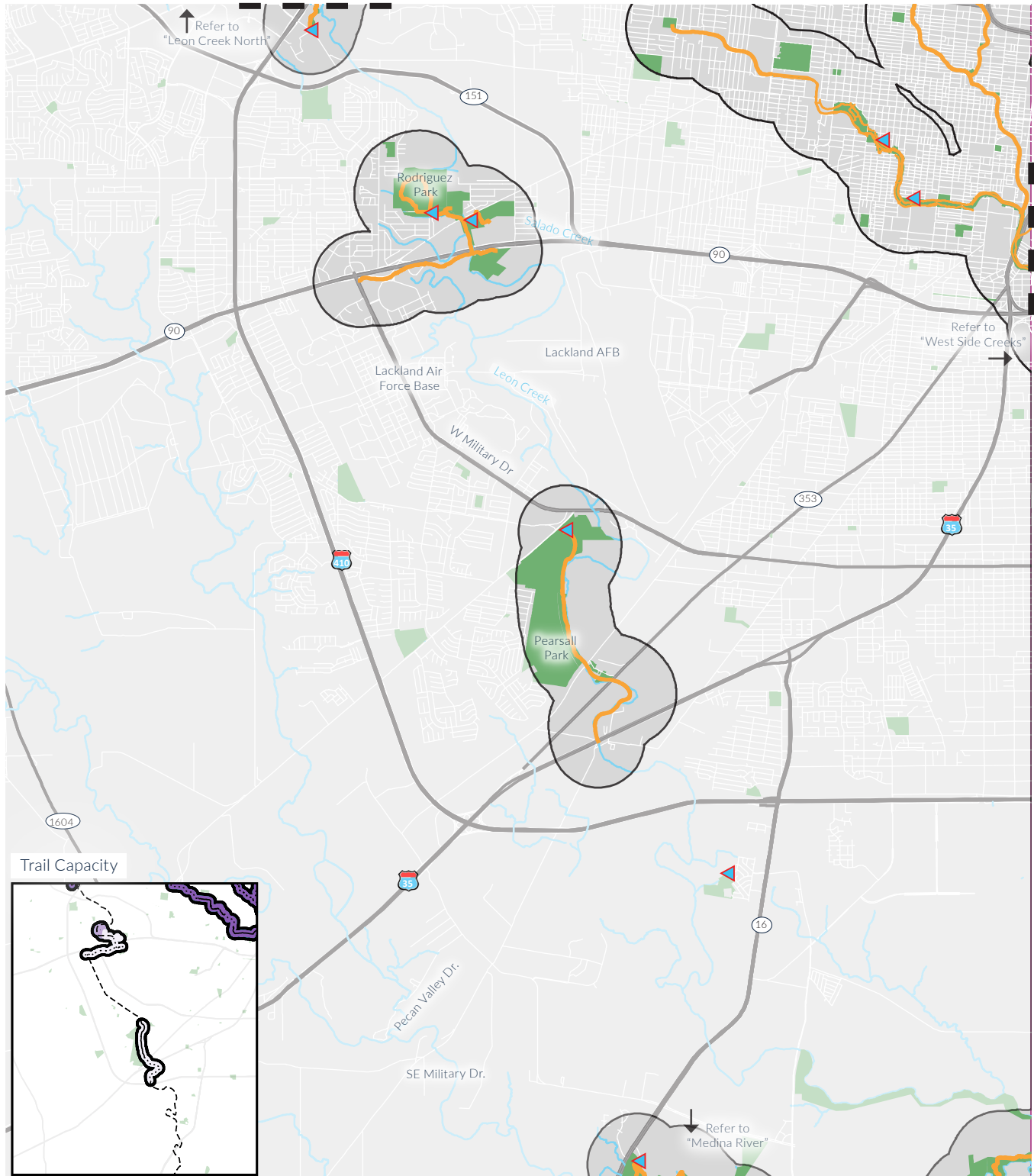

	Trail Capacity A		Trail Complete		Tier 2 Opportunities	
	Trail Capacity B		Trail Planned		1 Mile Buffer	
	Trail Capacity C		Tier 1 Opportunities			



# 4.6 LEON CREEK NORTH

The Leon Creek North Character Area is the system's most highly trafficked, as it connects heavily residential areas to major destinations such as UTSA, O.P. Schnabel Park, and Ingram Park Mall. Its suburban context affords it high amounts of canopy cover and natural creek beds. The high population density and high traffic demand mean the Leon Creek Character Area should have the highest Trail Capacity of any Character Area in the system.

PEOPLE

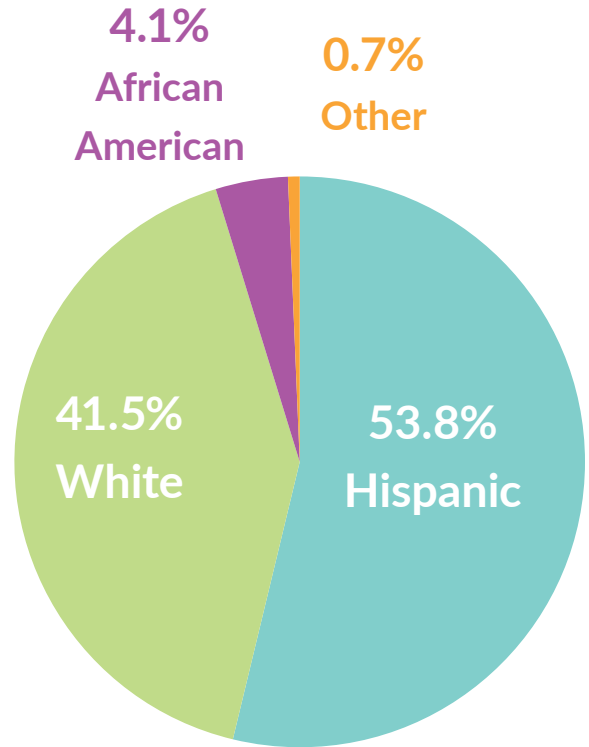

ENVIRONMENT

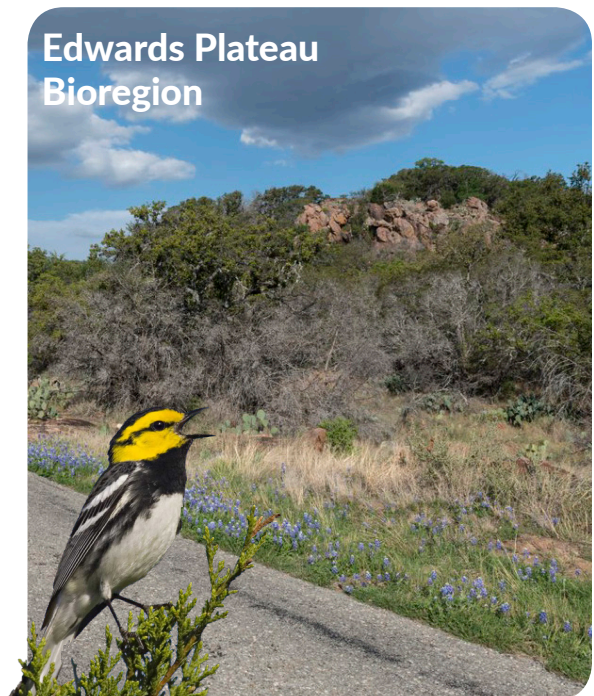
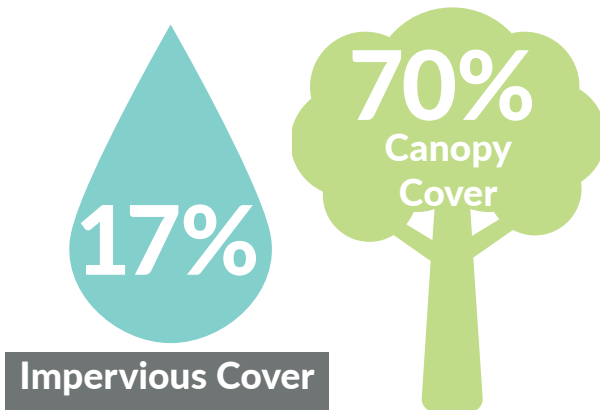



# LEON CREEK NORTH

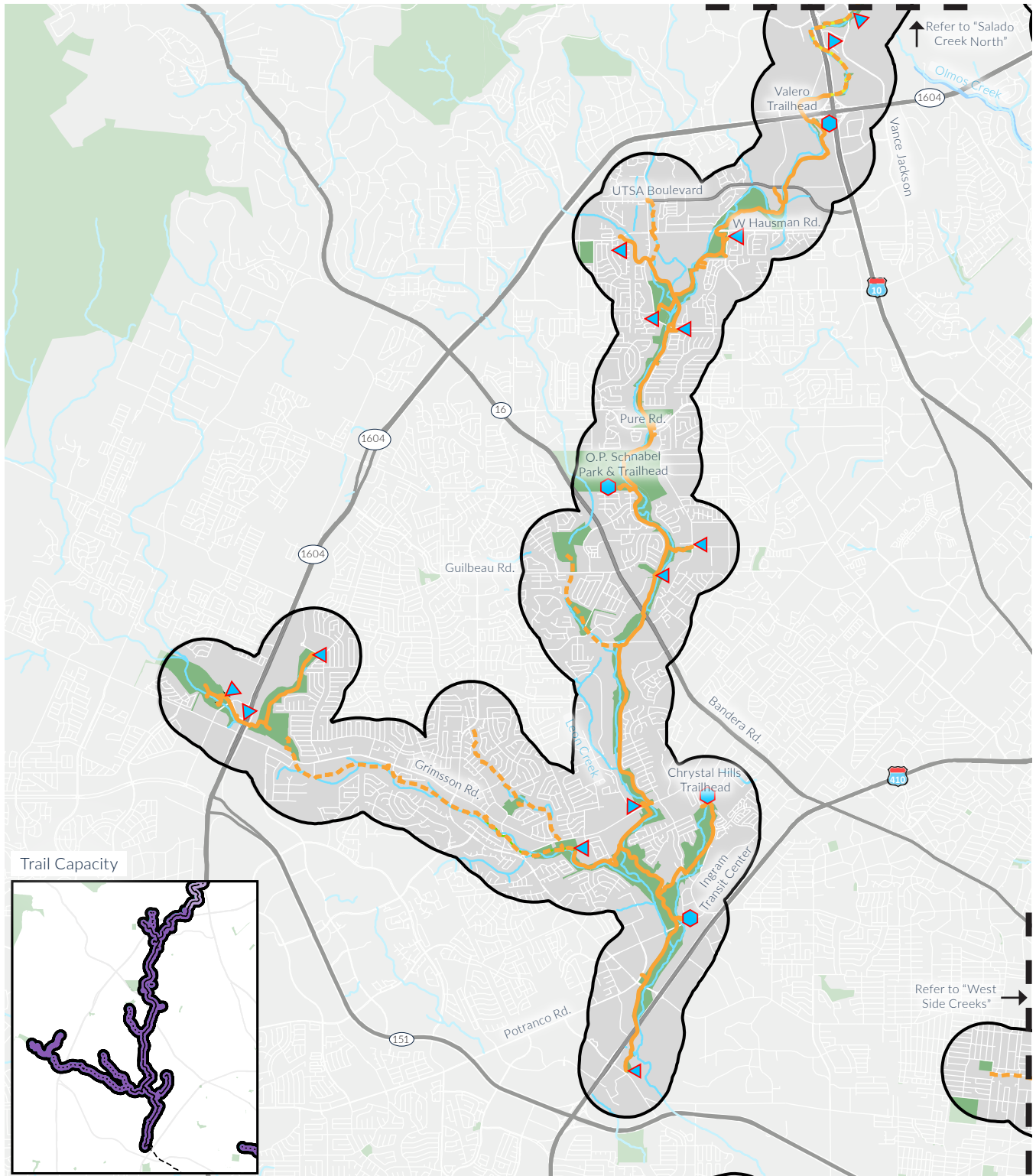

Trail Capacity

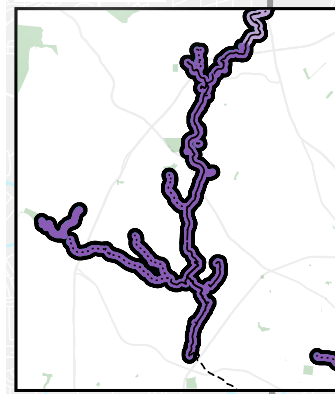

- Trail Capacity A
- Trail Capacity B
- Trail Capacity C
- Trail Complete
- Trail Planned
- Tier 1 Opportunities
- Tier 2 Opportunities
- 1 Mile Buffer



# 4.7 WEST SIDE CREEKS

The West Side Creeks are a network of small, mostly channelized creeks that penetrate the highly urbanized, densely populated West side neighborhoods. This Character Area has by far the most opportunity for improvement in terms of canopy cover and impervious cover, due to its urban setting. The trails also represent a significant opportunity for active transportation as they connect residential neighborhoods directly to major employment and transit centers in the downtown areas.

PEOPLE

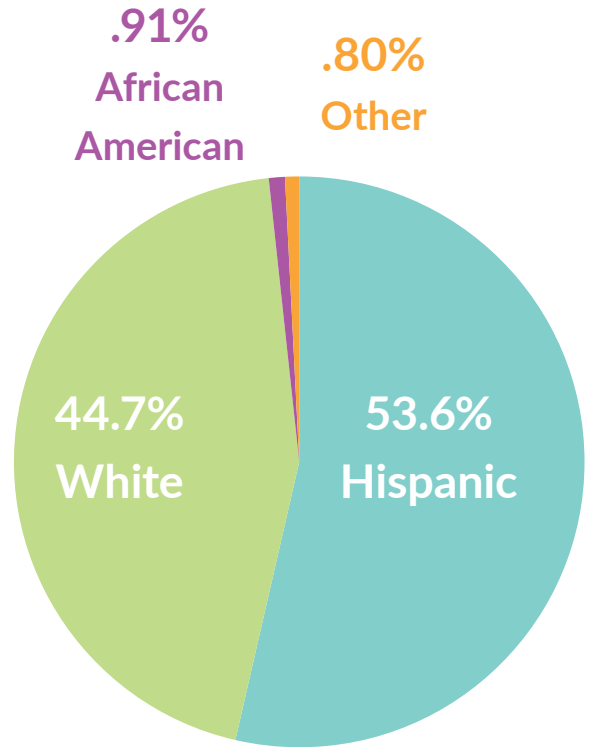

ENVIRONMENT

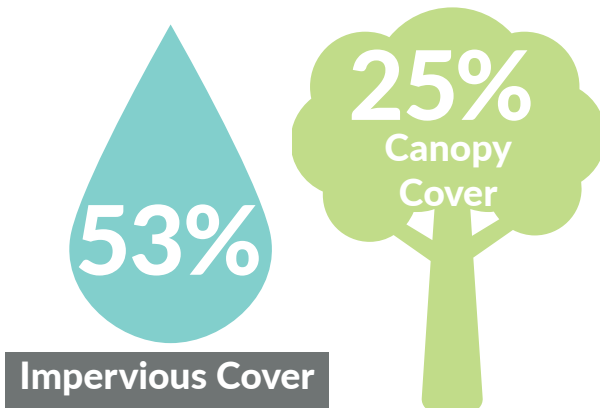

# WEST SIDE CREEKS

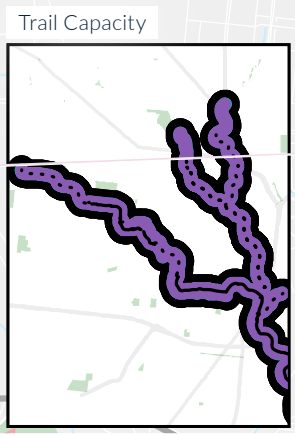
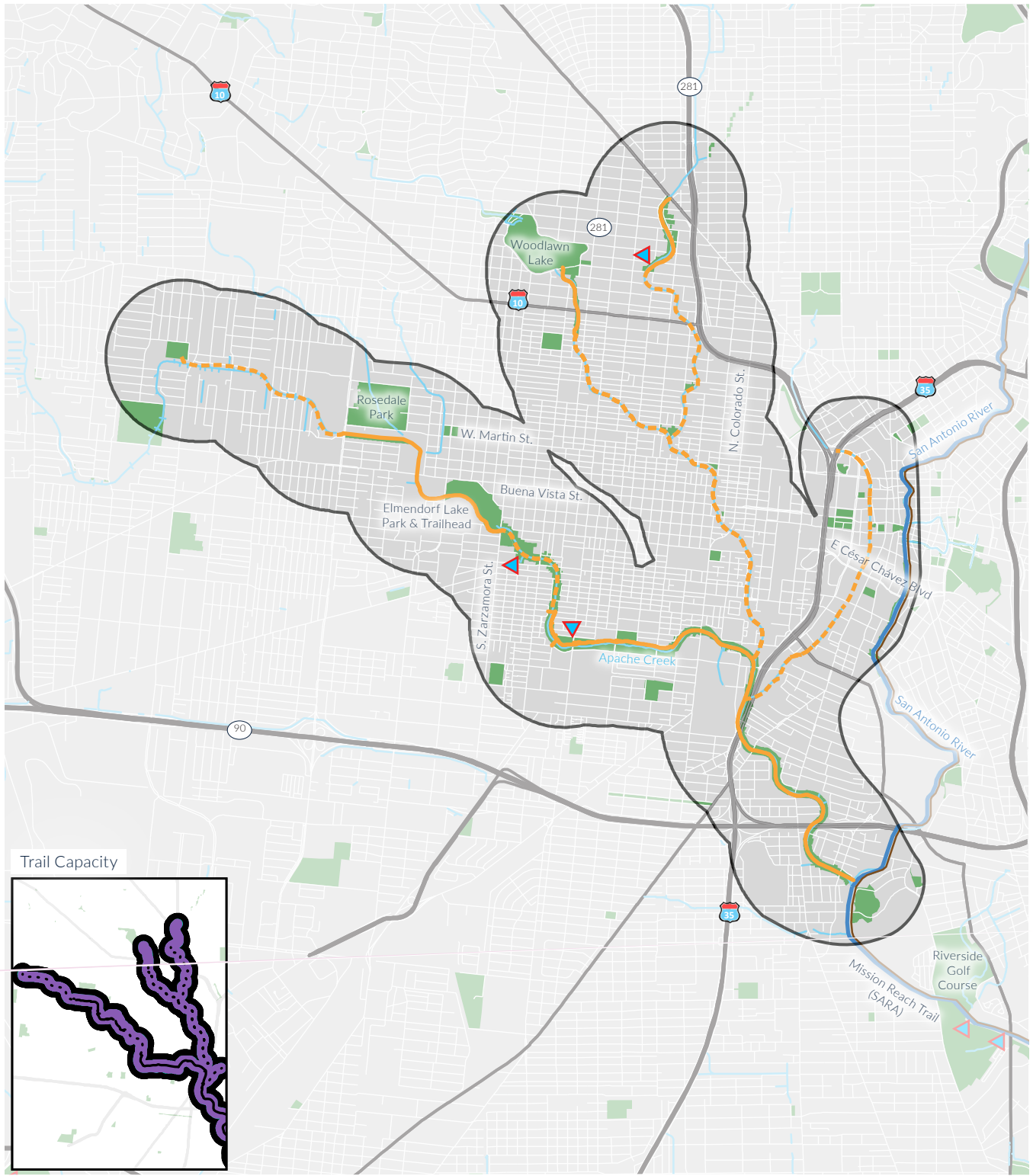

- Trail Capacity A
  Trail Complete
  Tier 2 Opportunities
- Trail Capacity B
  Trail Planned
  1 Mile Buffer
- Trail Capacity C
  Tier 1 Opportunity
  Museum and Mission Reach Trail

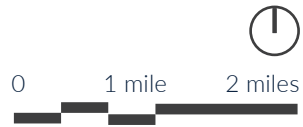

# 5 TRAIL INTERVENTIONS

Using the above site analysis and engagement with City stakeholders, the consultant team and City trail managers developed the following framework with which to unify future trail development under a common vision.

The framework breaks the system into six unique “Character Areas” which each will have unique aesthetic characteristics while also maintaining uniform quality standards and connectivity. Trail design specifications will be applied depending on the segment’s intended “Trail Capacity,” which was determined using an aggregate of factors including population density and frequency of trail usage. Finally, specific trail needs such as shade or flood infrastructure will be addressed using components specified in the system “Toolkit.” The toolkit will allow trail managers to uniformly install appropriate trail amenities and infrastructure and eliminate the need to individually design solutions across the trail system.







## A NATIONAL LOOK

In order to determine the appropriate baseline standards for width and other features of greenway system, National and Regional standards were assessed and are outlined here.

## TIER 1, AND TIER 2 SITES

As new trailheads are developed, the Parks and Recreation Department will need to prioritize investments in key areas based on site criteria. While existing and proposed Tier 1 and 2 sites are identified in this document per City staff input, the following criteria should be used in combination

## NATIONAL PRECEDENTS FOR TRAIL WIDTHS

	TRAIL TYPOLOGY	TRAIL WIDTH
FEDERAL HIGHWAY ADMINISTRATION	Two-Directional Trail	10' 12'-14' heavy use 8' adequate
NACTO	Conventional Bike Lane	6' min.
	Buffered Bike Lane	5' min., 7' desired
AUSTIN URBAN TRAILS MASTER PLAN	Typical Urban Trail	12'
	Dual-Track Urban Trail	5' for pedestrian side 10' for bicyclist side
HOUSTON BIKE PLAN	Off-Street Bike Path	12' desirable for two-way off-street bike path, 8' min
PORTLAND TRAIL DESIGN GUIDELINES	Walking and biking	8'-25' (10'-12' pref. maint. vehicles) 12'-25' for riverfront esplanades
ATLANTA BELT LINE	Shared-Use Path	14' (7' outer trail and 7' inner trail)
	Connecting Trail	Hard Trails: 4'-8' Soft Trails: 2' - 4'
DENVER MOVES: PEDESTRIAN AND TRAILS PLAN	Regional Trails	12'-18'
	Collecting and Local Trails	10'
STORY MILL PARK, BOZEMAN, MT	Commuter Biking	12'
	Connector Biking	10'

in the future to determine new sites for Tier 1 trailheads as well as key opportunities to improve existing trailheads to a standard aligned with Tier 1 expectations.

VARIABLE	WEIGHT
Within high use area	High
On arterial street	High
Within .25 miles of Bicycle Plan nodes and corridors	Medium
Within .25 miles of an SA Corridor	Medium
Within .5 miles of proposed TOD station	Medium
Within .5 miles of SA activity center	Medium
Within .25 miles of VIA transit center or multi-modal center	Medium
City owned land adjacent to creek	Medium
Within medium use area	Low
Within .5 miles of military base	Low
Within high density census tract	Low
Within low income census tract	Low
Within non-white plurality census tract	Low
Within .25 miles of commercial land use	Low

Criteria were determined based on a variety of factors, including the opportunity to align with other City plans and policies, the opportunity to meet demand in high-traffic and high-use areas (or those with that potential), as well as promote equity in providing quality trails assets.

## RECOMMENDED TRAIL WIDTHS

### TRAIL CAPACITY A

To address the trail demand in the most densely populated, highest use segments of trail, Trail Capacity A provides 14' of usable trail space. Trail Capacity A is applicable in areas where there will be high demand on the trail as both a recreation and transportation corridor to accommodate the higher traffic demand safely and efficiently.



### TRAIL CAPACITY B

This category will be most appropriate in areas of high recreational use and moderate transportation use. At 12', this is the trail capacity of most of the current trail system, however under the new standards it would be uniformly applied throughout the identified Trail Capacity B area.



### TRAIL CAPACITY C

Trail Capacity C is applicable in rural and suburban areas where the trail is predominantly a recreational corridor. 10' is still wide enough to accommodate both bicycle and pedestrian traffic safely and efficiently, though user conflict may exist in certain areas at certain times. The narrower right of way will decrease impact on the corridor ecology.

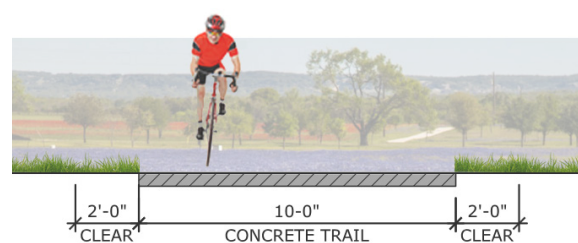

# 6 DESIGN TOOLKITS

A unified palette of furnishings for the HWP Greenway Trail System provides branding and an enhanced aesthetic system-wide. This Toolkit proposes custom shade structures for each Character Area with a materiality that complements easily procured “off-the-shelf” items. The furnishings proposed will be factory powder-coated with the Character Area colors.

Creek beds, often with steep slopes and regular flooding, are challenging places to build. Because of this, there are many areas where long, continuous runs of retaining walls are needed. Currently, there are many types of retaining walls being used throughout the trail system, including pour in place concrete, concrete with stencils, stone masonry, and gunnite. A unified and consistent palette of attractive, contemporary, and cost effective retaining walls is recommended by this Trail Design Strategy to give the trail system cohesion and identity.

As a steward of sensitive riparian areas, the City is committed to reducing environmental impact as much as possible by utilizing low impact development (LID) techniques. The intent of these tools is to reduce runoff from impervious surfaces, such as parking lots, and should be used whenever constructing new Tier 1 trailheads or upgrading existing trailheads with parking facilities.

A tree species selection matrix and pollinator plant list is also included in this section to assist consultants with locating the most appropriate species within various diverse growing conditions.



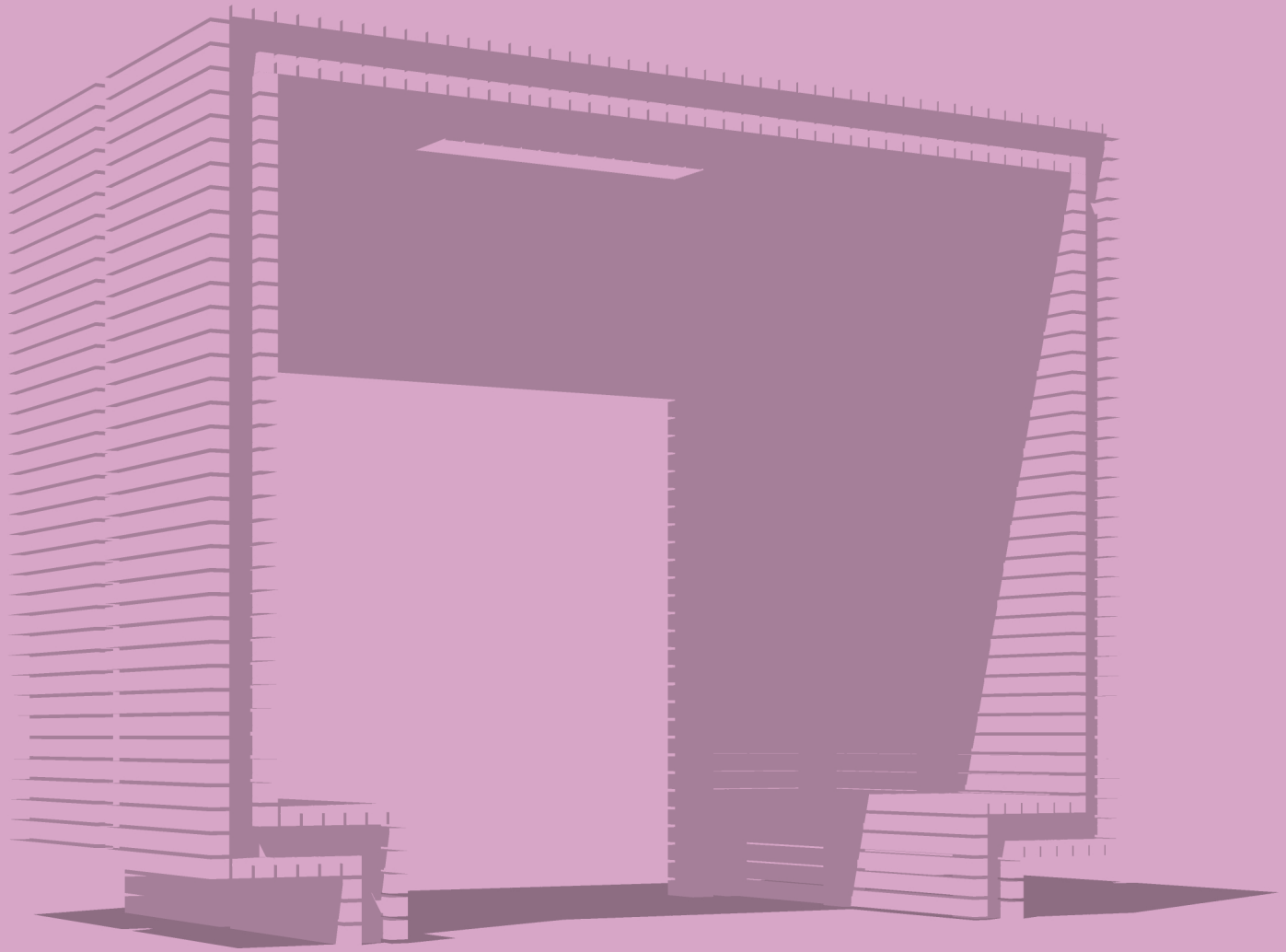

# 6.1 MEDINA RIVER

## SHADE STRUCTURE

The Medina River is the most wild and least disturbed part of the trail system. The organic curved lines of the powder-coated steel beams reference the many twists and turns of the river. Simple wood columns, wood cladding, an integrated board-formed concrete bench, and oversized black steel post bases offer a rugged yet refined aesthetic.

## CHARACTER AREA COLOR



Bald Cypress Green  
RAL 6019  
RGB 185, 206, 172

The Medina River is the most undeveloped Character Area. The majestic Bald Cypress trees lining its bank are its most striking natural features.

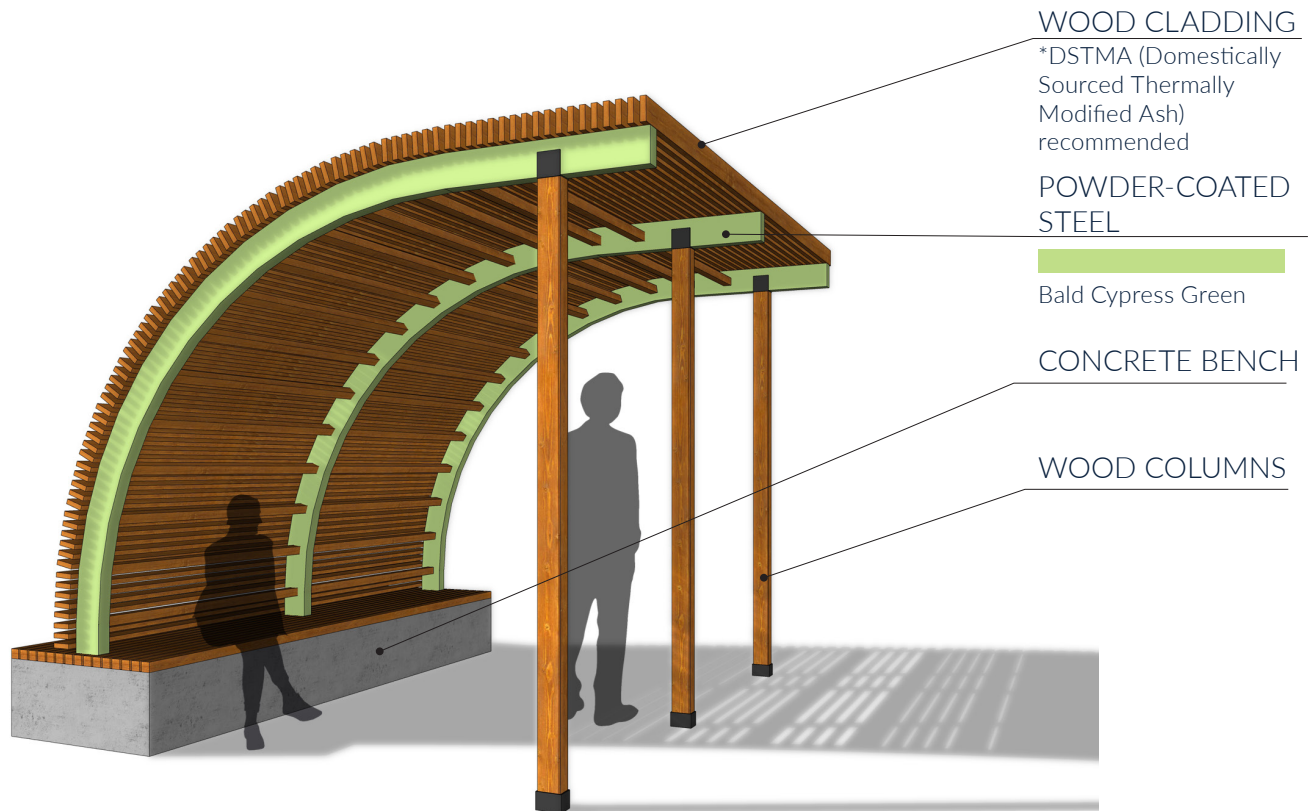

\*If City policy mandates, transversal bars or armrests can be added to benches to comply

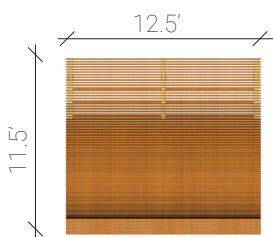

TOP

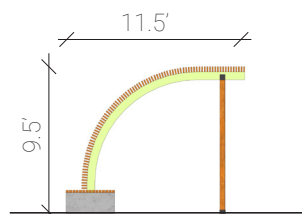

LEFT

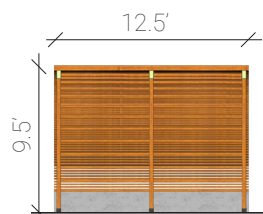

FRONT

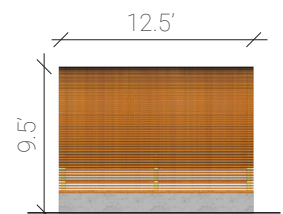

BACK

## FURNISHINGS

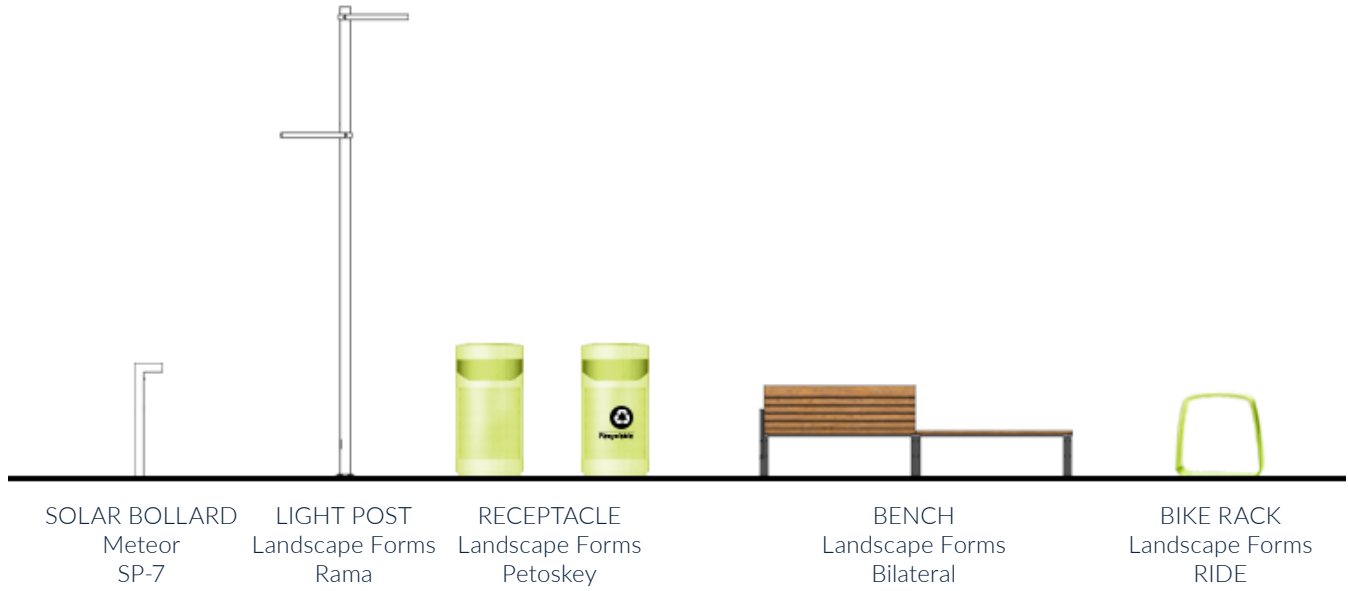

\*Character Area colors will also apply to other elements out of the scope of this project, such as water fountains, components of restroom enclosures, etc. Actual details on these to be developed by each construction project.

## ALTERNATES

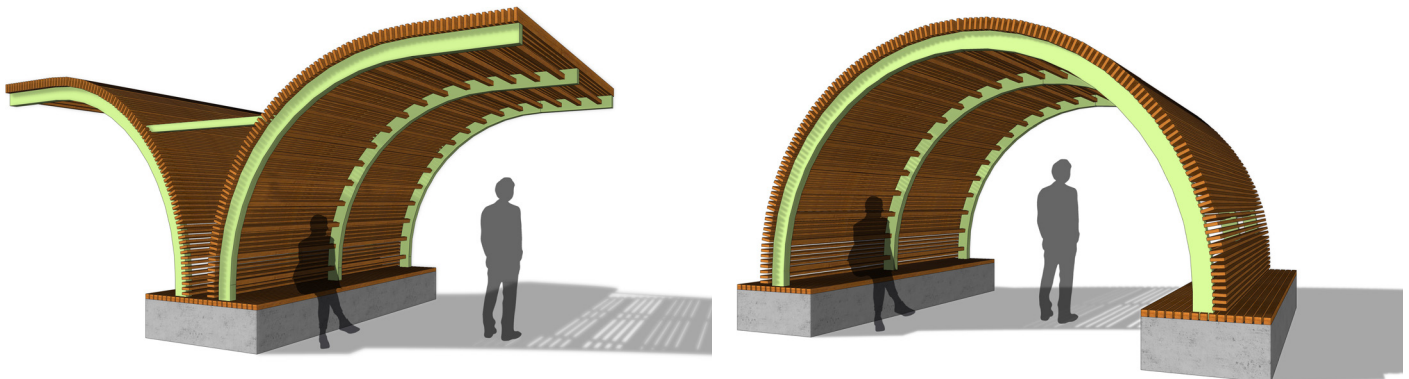

MIRRORED CONFIGURATION

HANGAR CONFIGURATION

# FURNISHINGS FAMILY

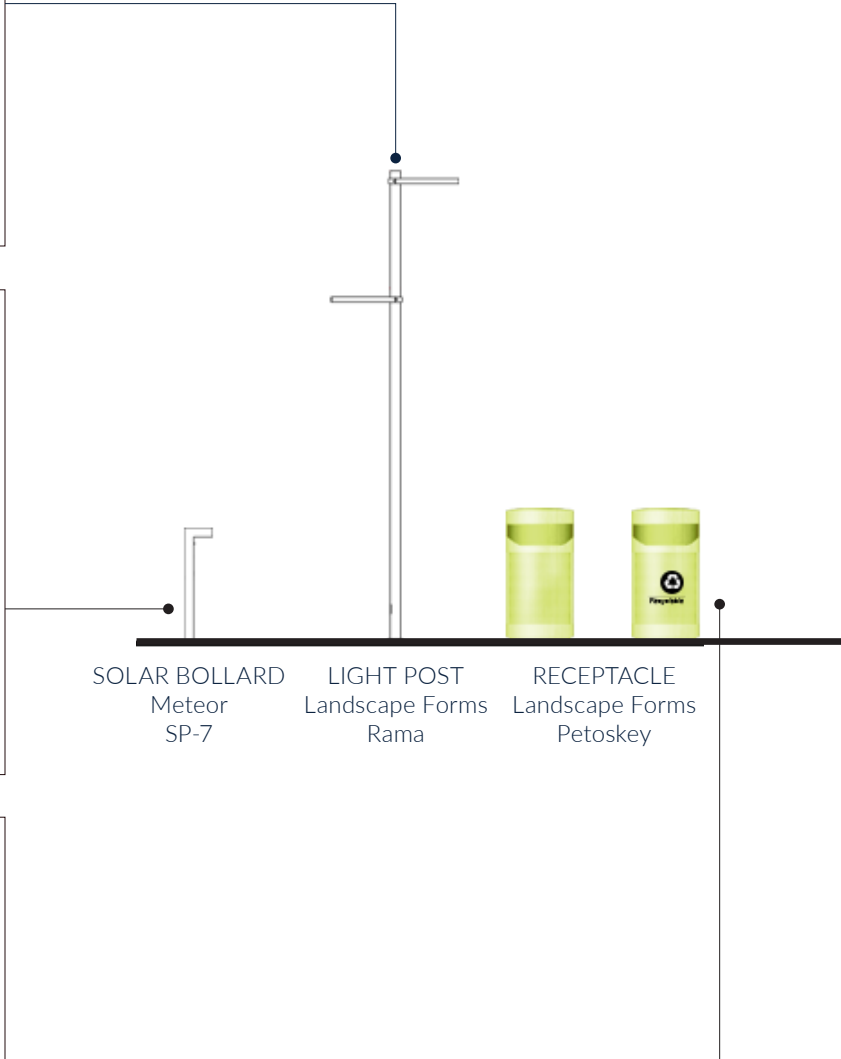

SOLAR BOLLARD  
Meteor  
SP-7

LIGHT POST  
Landscape Forms  
Rama

RECEPTACLE  
Landscape Forms  
Petoskey





BENCH  
Landscape Forms  
Bilateral

BIKE RACK  
Landscape Forms  
RIDE

Landscape Forms Grentchen  
Without umbrella hole  
Wood: Ipe

# 6.2 SALADO CREEK SOUTH

## SHADE STRUCTURE

The offset angles of this shade structure are inspired by the jagged faults of the region's most iconic geologic feature - the Balcones Escarpment. Cor-ten panels offer a durable yet contemporary aesthetic. An integrated bench provides different depths of seating, allowing trail users to either sit or rest with their feet up. While this option is consistent with Salado Creek North, color changes to the powder-coated metal offer an opportunity to differentiate between the two.

### CHARACTER AREA COLOR



Monarch Butterfly Orange  
RAL 1003  
RGB 249, 168, 0

Located in several important migration routes, Salado Creek's natural areas contain vital habitat for the iconic Monarch Butterfly

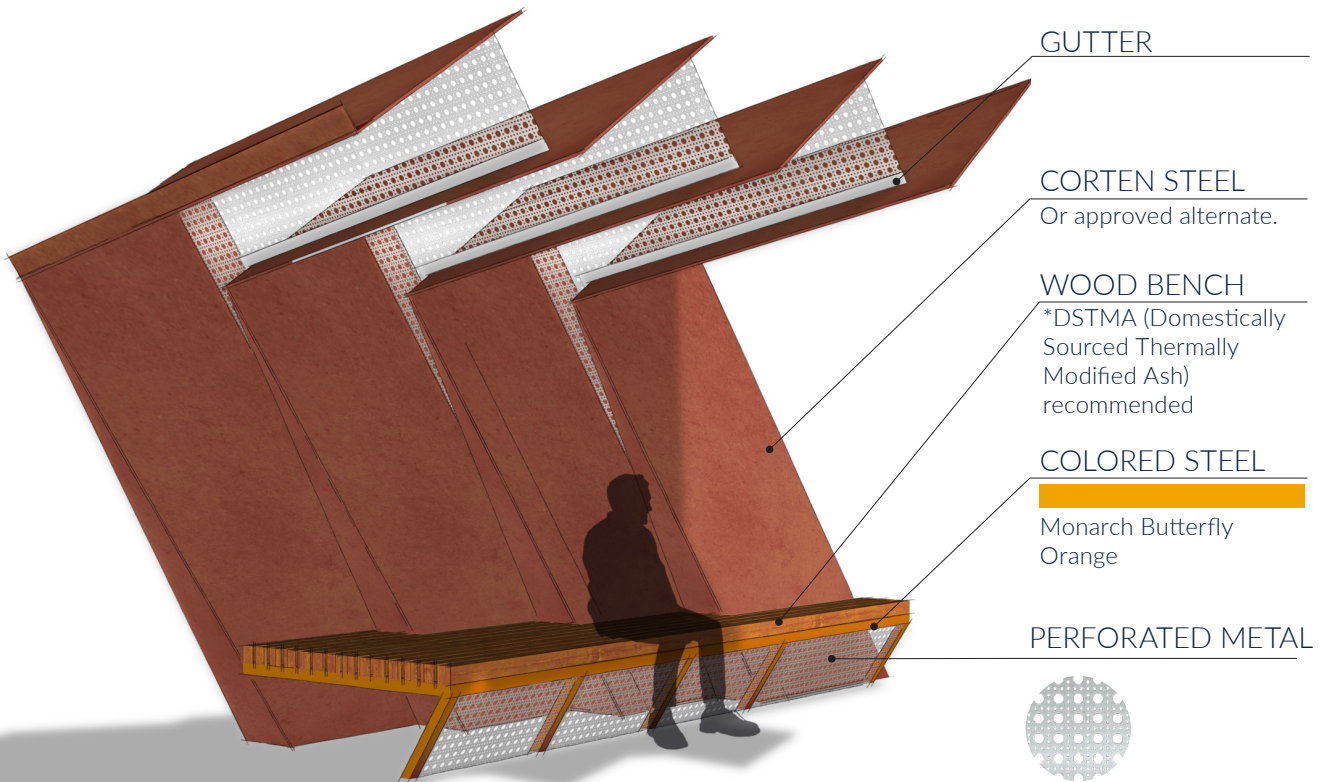

\*If City policy mandates, transversal bars or armrests can be added to benches to comply

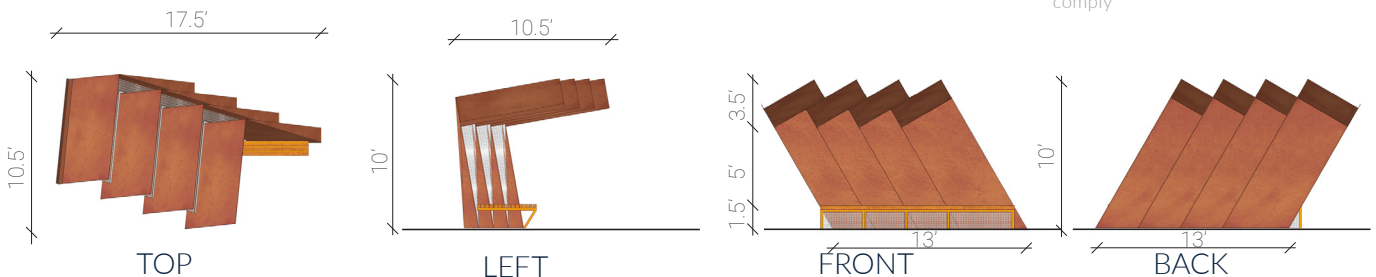

## FURNISHINGS

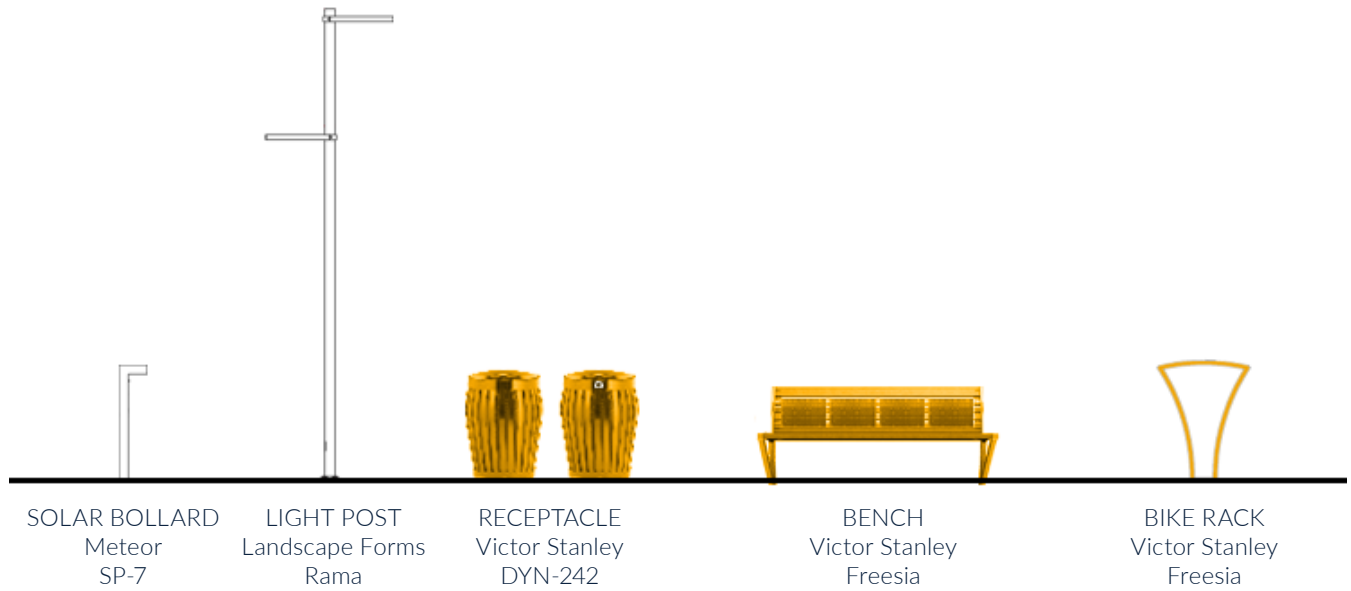

\*Character Area colors will also apply to other elements out of the scope of this project, such as water fountains, components of restroom enclosures, etc. Actual details on these to be developed by each construction project.

## ALTERNATES

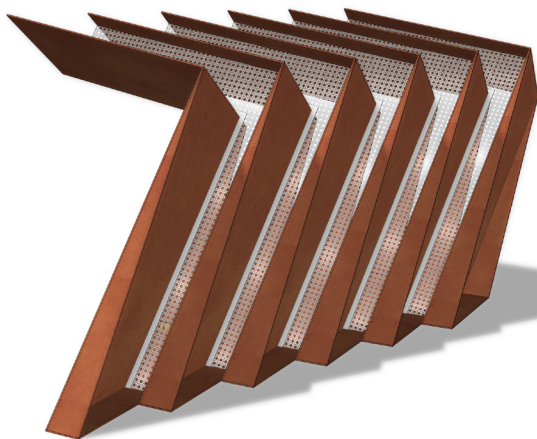

EXTENDED LENGTH

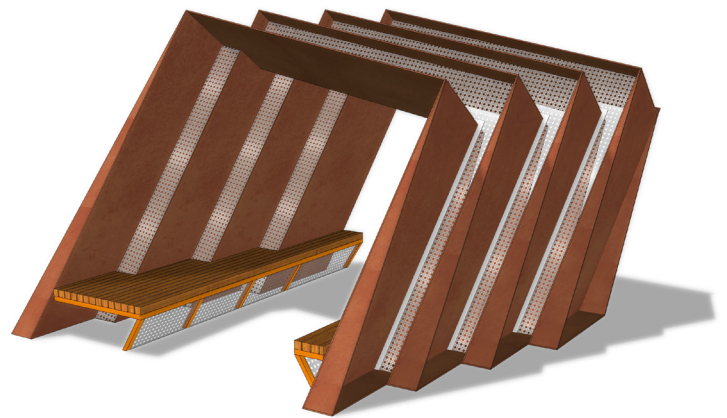

FULL WRAP

# FURNISHINGS FAMILY

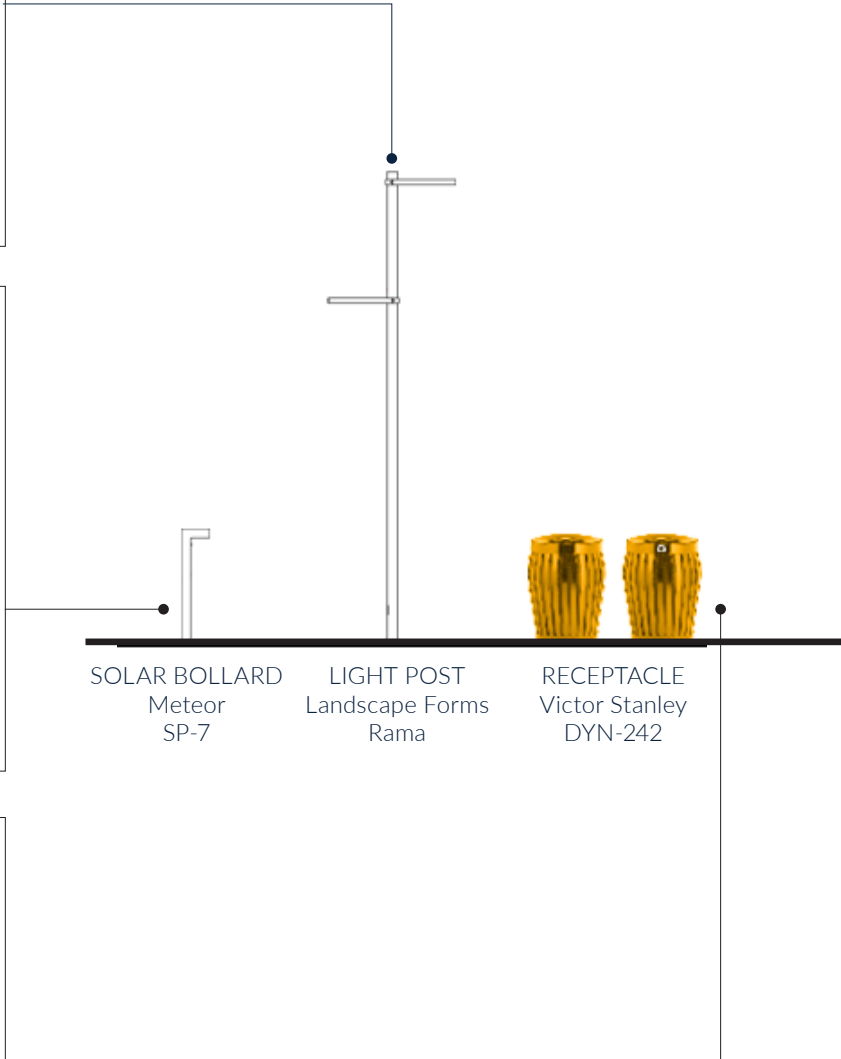
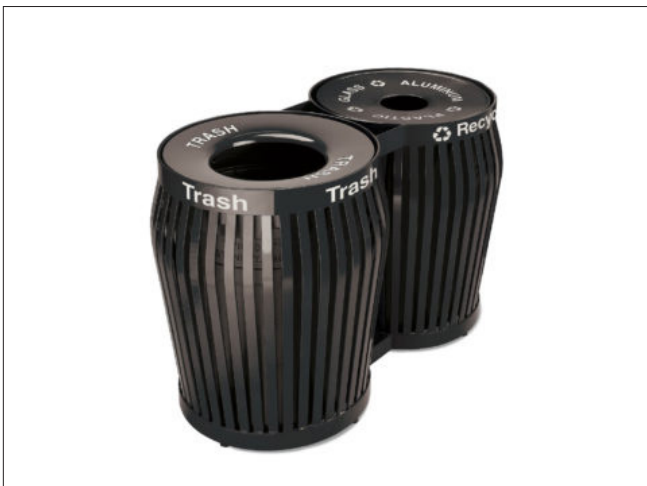

SOLAR BOLLARD Meteor SP-7      LIGHT POST Landscape Forms Rama      RECEPTACLE Victor Stanley DYN-242





BENCH  
Victor Stanley  
Freesia

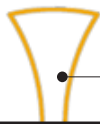

BIKE RACK  
Victor Stanley  
Freesia



Victor Stanley Camille  
CAMT-43  
Wood slats

# 6.3 SALADO CREEK NORTH

## SHADE STRUCTURE

The offset angles of this shade structure are inspired by the jagged faults of the region's most iconic geologic feature - the Balcones Escarpment. Cor-ten panels offer a durable yet contemporary aesthetic. An integrated bench provides different depths of seating, allowing trail users to either sit or rest with their feet up. While this option is consistent with Salado Creek South, color changes to the powder-coated metal offer an opportunity to differentiate between the two.

### CHARACTER AREA COLOR

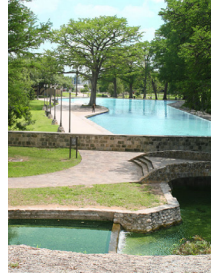

Artesian Blue  
RAL 6027  
RGB 126, 186, 181

Salado Creek, once a reliable artesian spring-fed stream full of aquatic life, nearly dried up at the turn of the century. Today, it has been restored.

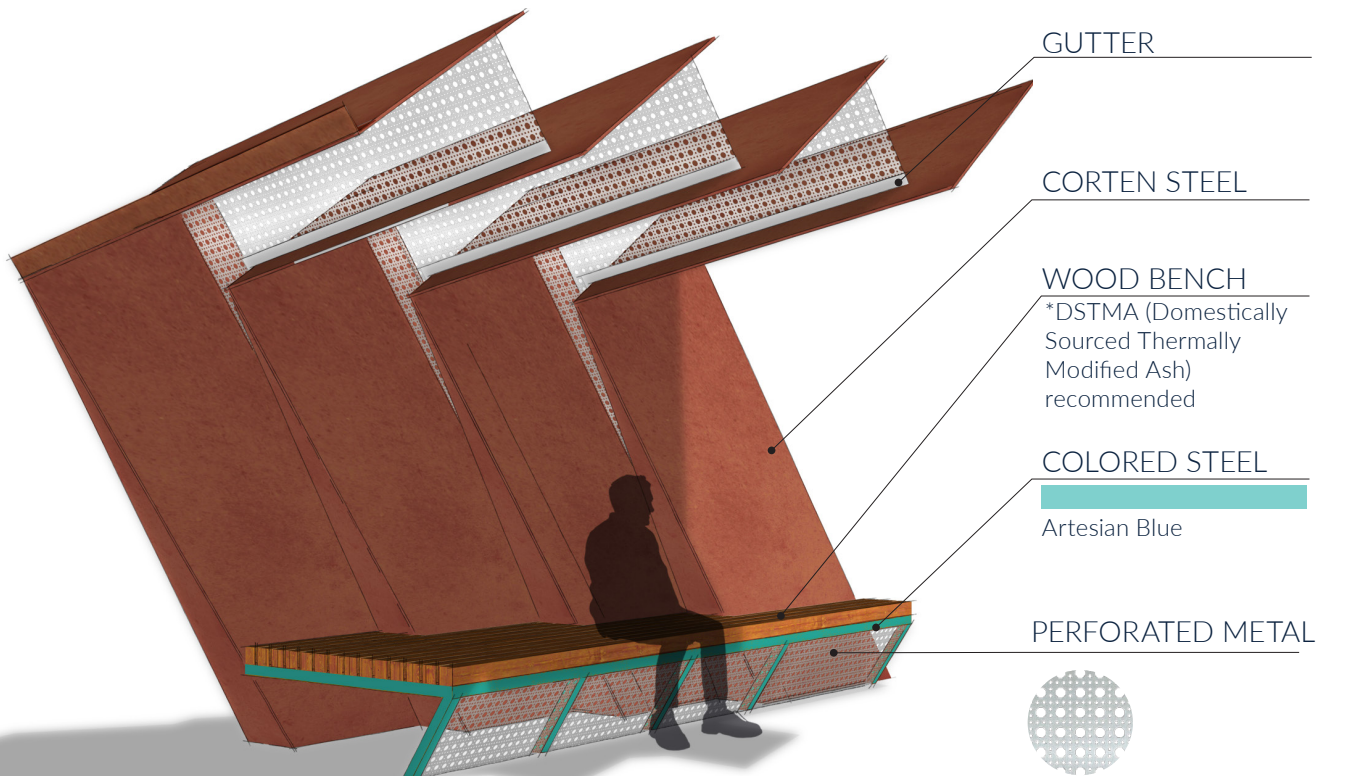

\*If City policy mandates, transversal bars or armrests can be added to benches to comply

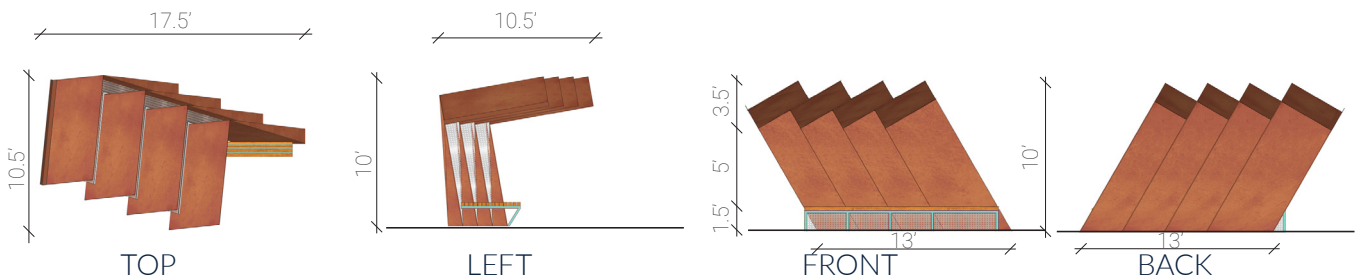

## FURNISHINGS

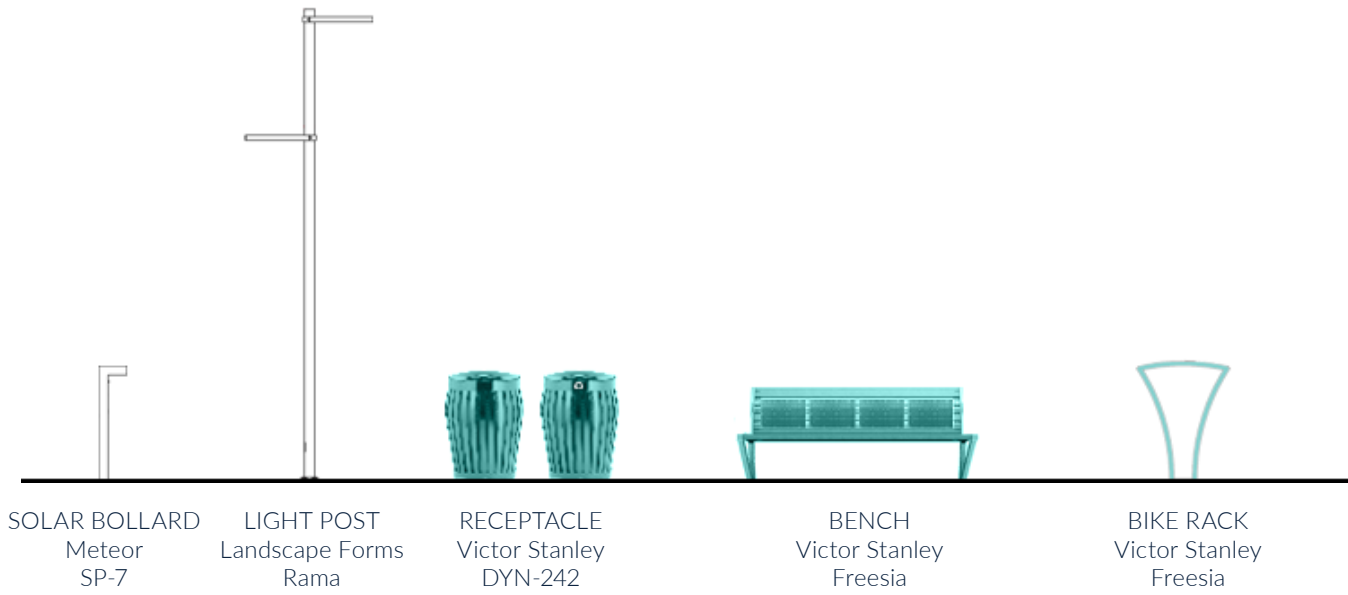

\*Character Area colors will also apply to other elements out of the scope of this project, such as water fountains, components of restroom enclosures, etc. Actual details on these to be developed by each construction project.

## ALTERNATES

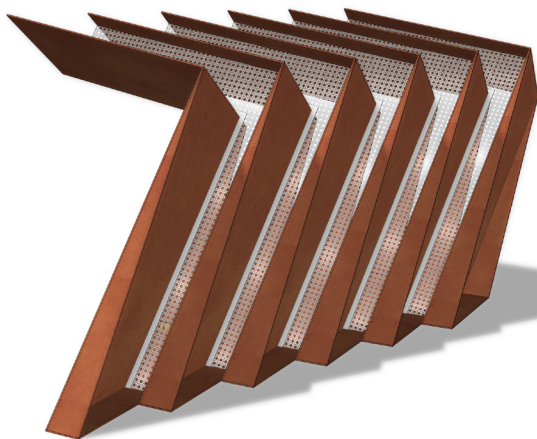

EXTENDED LENGTH

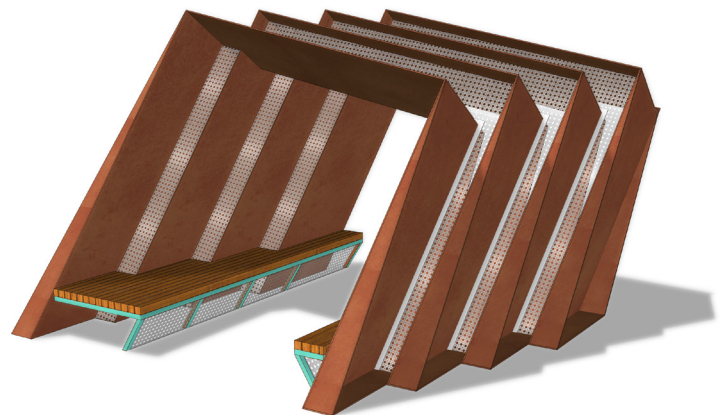

FULL WRAP

# FURNISHINGS FAMILY

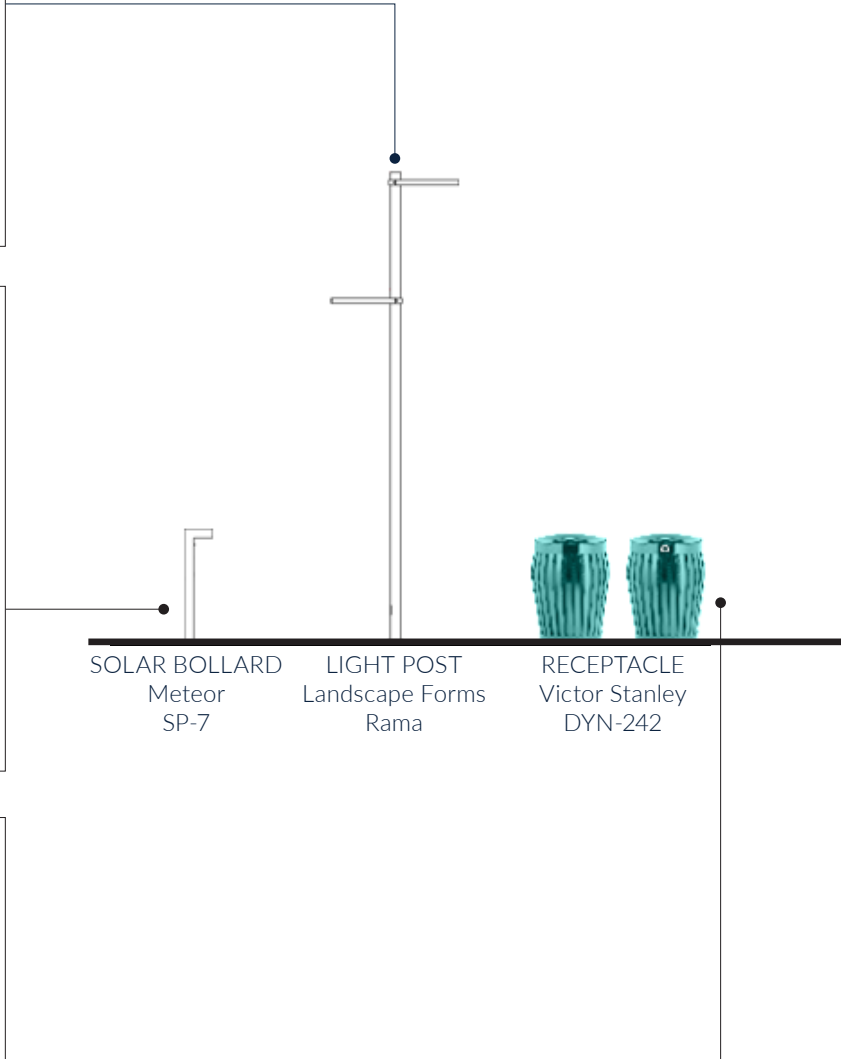

SOLAR BOLLARD  
Meteor  
SP-7

LIGHT POST  
Landscape Forms  
Rama

RECEPTACLE  
Victor Stanley  
DYN-242



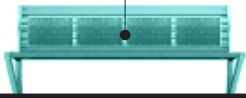

BENCH  
Victor Stanley  
Freesia



BIKE RACK  
Victor Stanley  
Freesia



Victor Stanley Camille  
CAMT-43  
Wood slats

# 6.4 LEON CREEK SOUTH

## SHADE STRUCTURE

Inspired by a modern design aesthetic, this shade structure consists of offset wood cladding supported by a steel frame. The wrapped walls provide maximum solar protection while the spacing allows for visual transparency and breezes. A perforated metal “skylight” casts intricate patterns onto the floor below. This shade structure also provides some of the most substantial shade relative to other Character Areas - an important consideration for an area with minimal tree canopy. While this option is consistent with Leon Creek North, color changes to the powder-coated metal offer an opportunity to differentiate between the two.

## CHARACTER AREA COLOR



Air Force Blue  
RAL 5013  
RGB 25, 49, 83

Leon Creek connects the rapidly growing UTSA area to the Hill Country ecoregion and Lackland Air Force Base to the South.

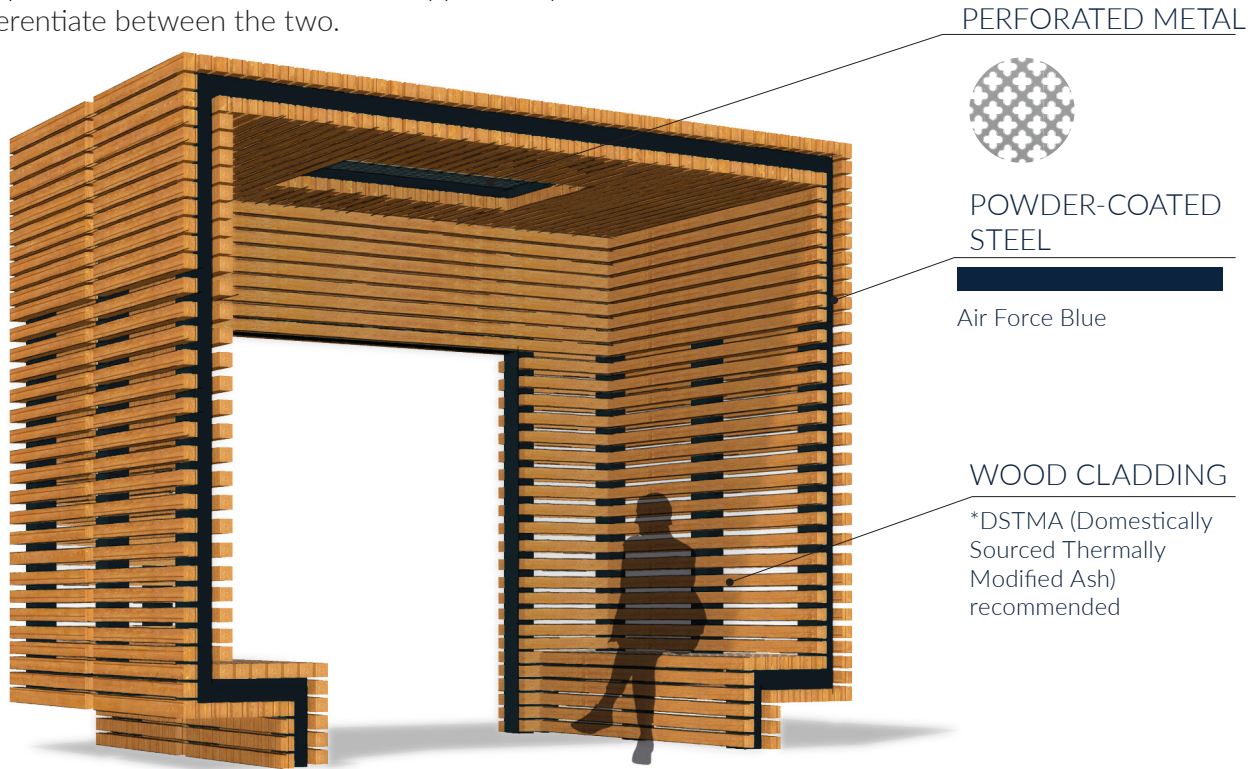

\*If City policy mandates, transversal bars or armrests can be added to benches to comply

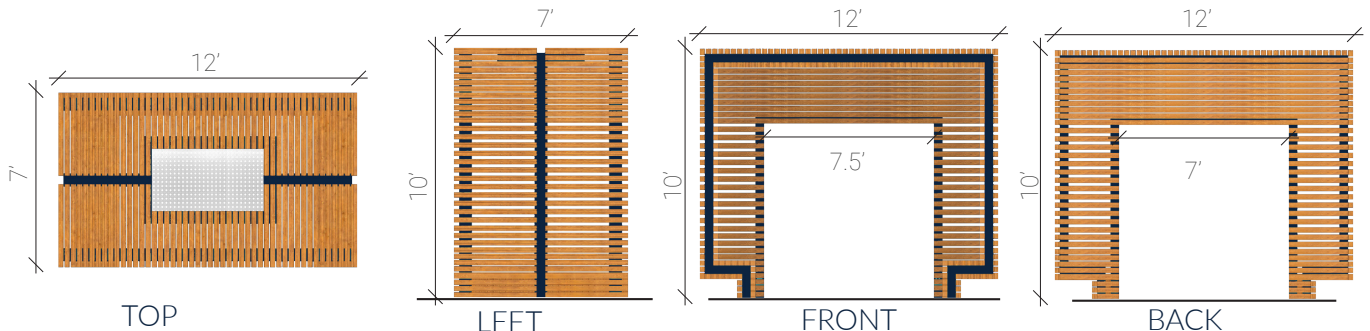

## FURNISHINGS

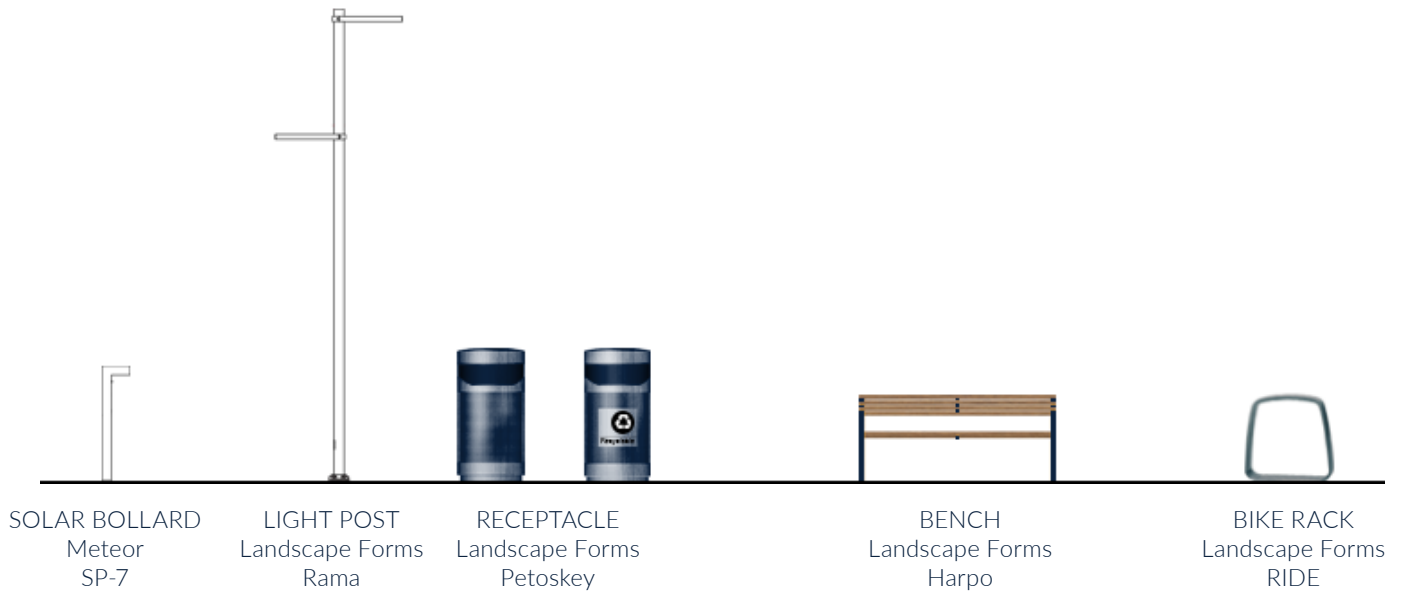

\*Character Area colors will also apply to other elements out of the scope of this project, such as water fountains, components of restroom enclosures, etc. Actual details on these to be developed by each construction project.

## ALTERNATES



# FURNISHINGS FAMILY

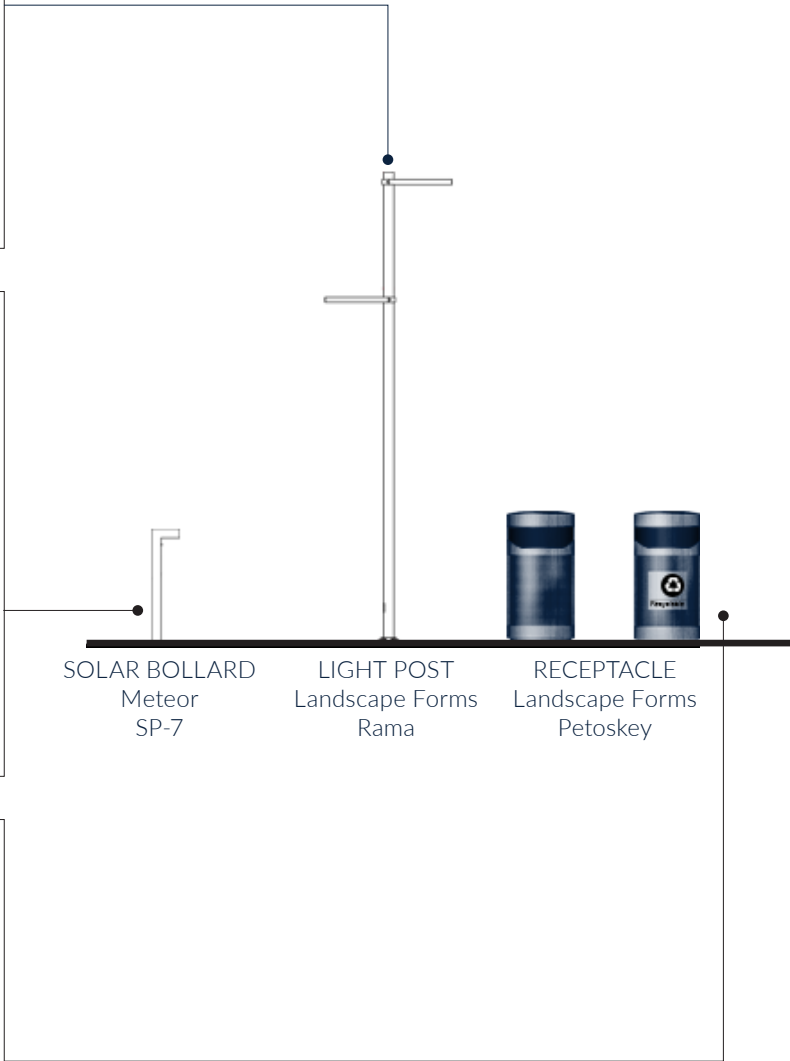





BENCH  
Landscape Forms  
Harpo



BIKE RACK  
Landscape Forms  
RIDE



Landscape Forms Harpo  
Narrow slats  
Wood

\*Backless Landscape Forms Harpo benches will be paired with this picnic table option

# 6.5 LEON CREEK NORTH

## SHADE STRUCTURE

Inspired by a modern design aesthetic, this shade structure consists of offset wood cladding supported by a steel frame. The wrapped walls provide maximum solar protection while the spacing allows for visual transparency and breezes. A perforated metal “skylight” casts intricate patterns onto the floor below. This shade structure also provides some of the most substantial shade relative to other Character Areas - an important consideration for an area with minimal tree canopy. While this option is consistent with Leon Creek South, color changes to the powder-coated metal offer an opportunity to differentiate between the two.

### CHARACTER AREA COLOR



Prickly Pear Purple  
RAL 4006  
RGB 144, 51, 115

The Prickly Pear Cactus and its brightly colored fruits are an iconic plant for the entire region and are commonly found nearby.

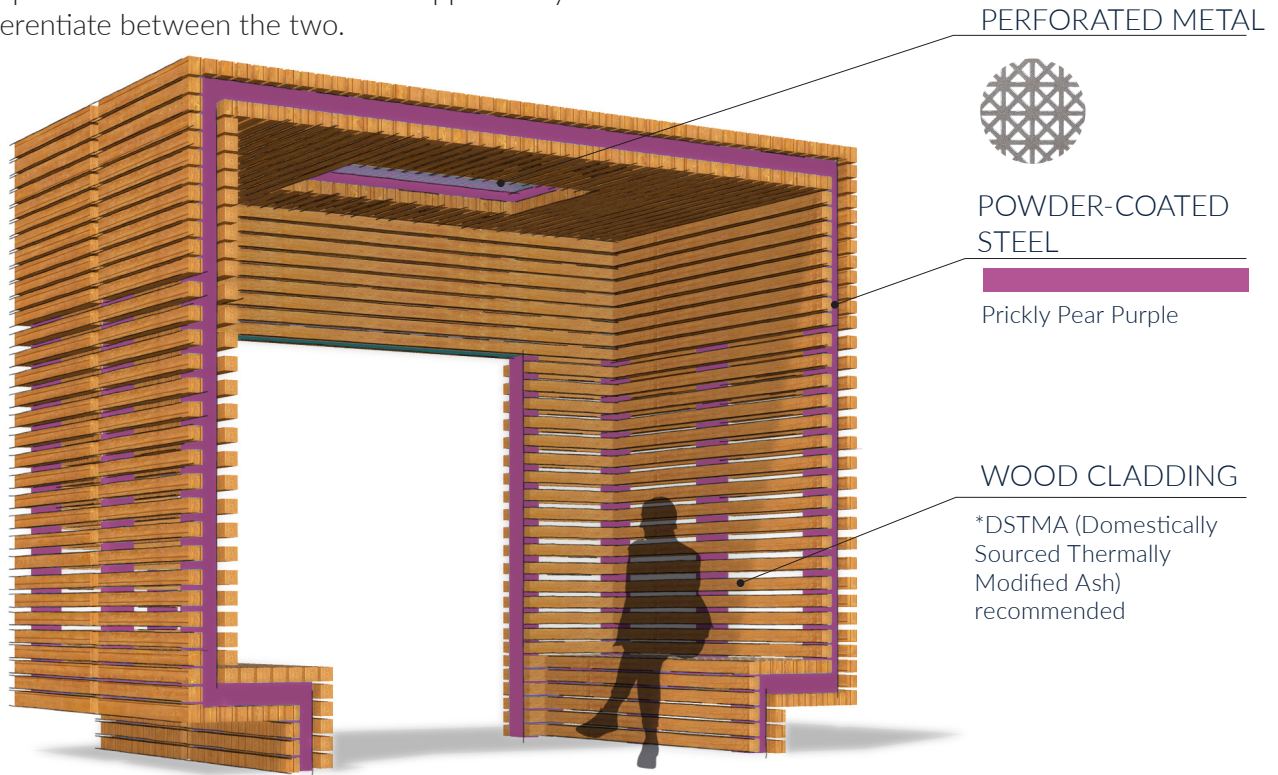

\*If City policy mandates, transversal bars or armrests can be added to benches to comply

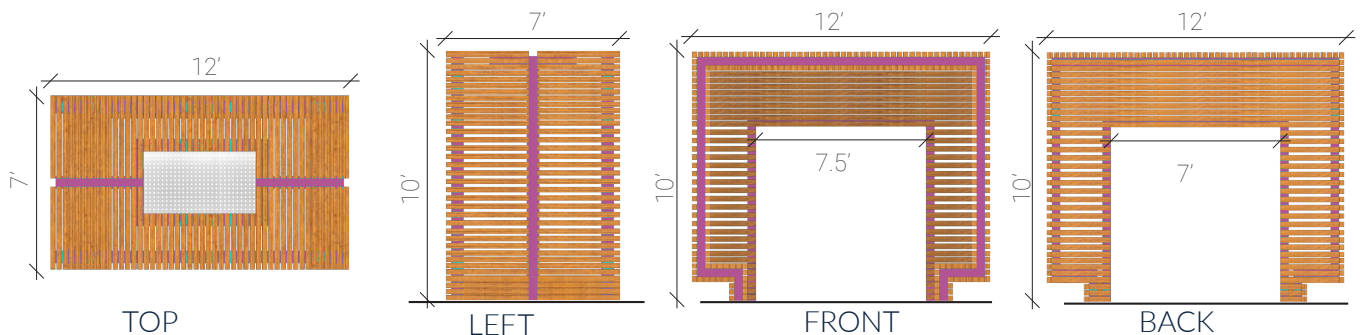

## FURNISHINGS

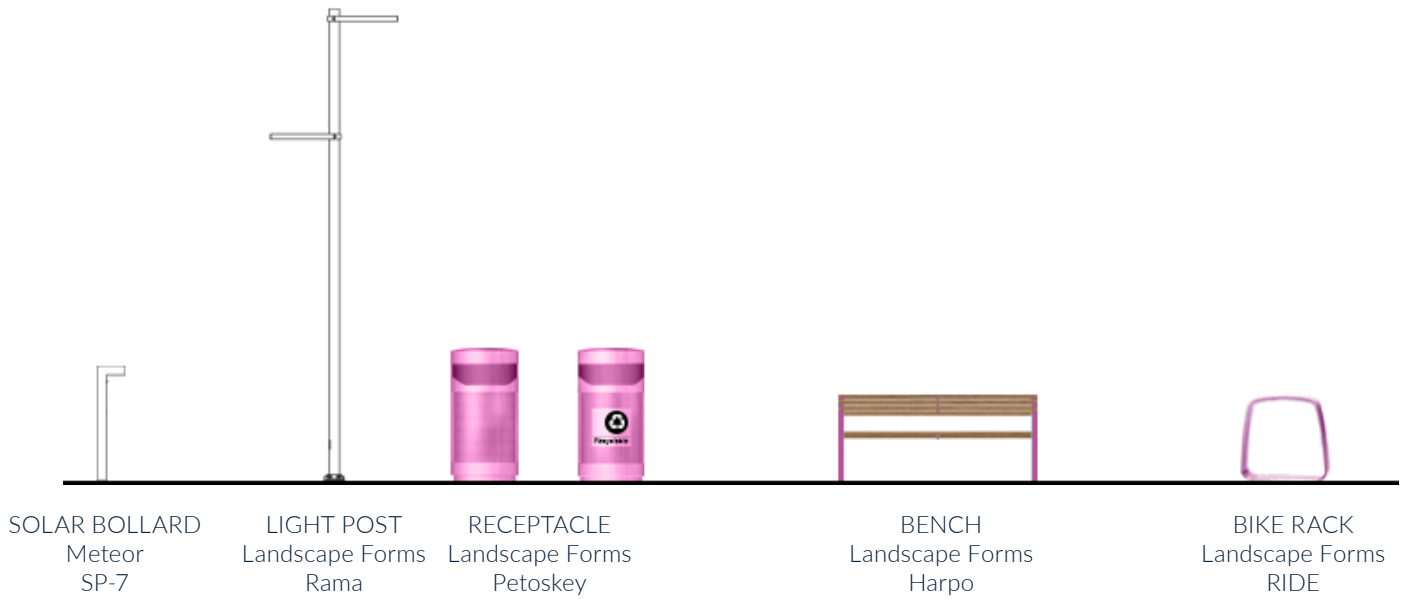

\*Character Area colors will also apply to other elements out of the scope of this project, such as water fountains, components of restroom enclosures, etc. Actual details on these to be developed by each construction project.

## ALTERNATES

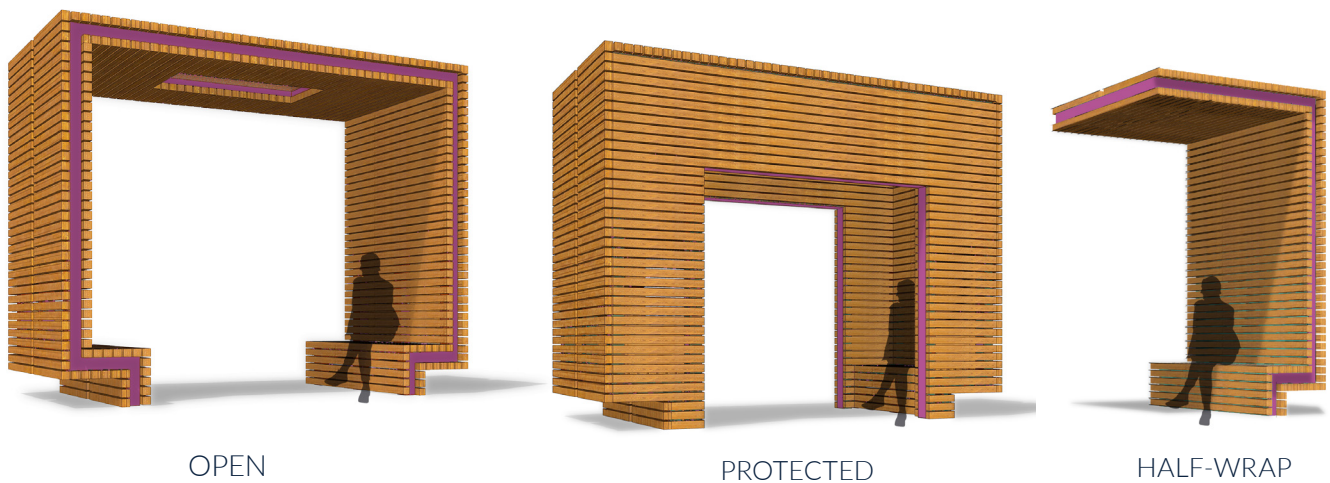

# FURNISHINGS FAMILY

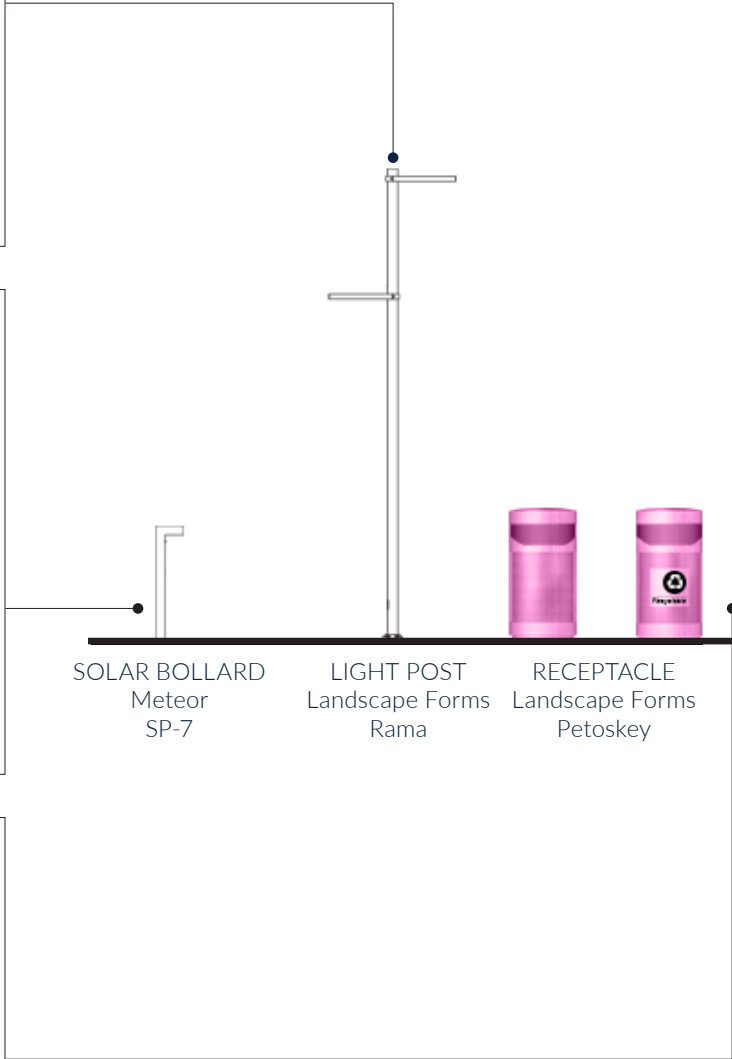

SOLAR BOLLARD  
Meteor  
SP-7

LIGHT POST  
Landscape Forms  
Rama

RECEPTACLE  
Landscape Forms  
Petoskey



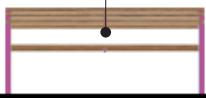

BENCH  
Landscape Forms  
Harpo



BIKE RACK  
Landscape Forms  
RIDE



Landscape Forms Harpo  
Narrow slats  
Wood

\*Backless Landscape Forms Harpo benches will be paired with this picnic table option

# 6.6 WEST SIDE CREEKS

## SHADE STRUCTURE

The Westside Creek's trails are almost entirely in floodplains. The robust "wickets" of this structure minimize the amount of damage that would occur during flooding. The channelized banks are almost totally devoid of tree coverage, and shade structures may be required at more regular intervals. The simple construction minimizes costs, allowing for shade at more frequent intervals.

### CHARACTER AREA COLOR



Enchilada Red

RAL 2010

RGB 208, 93, 40

Enchilada Red is a color frequently used in a variety of ways at local restaurants, convenience stores, and murals on the Westside.

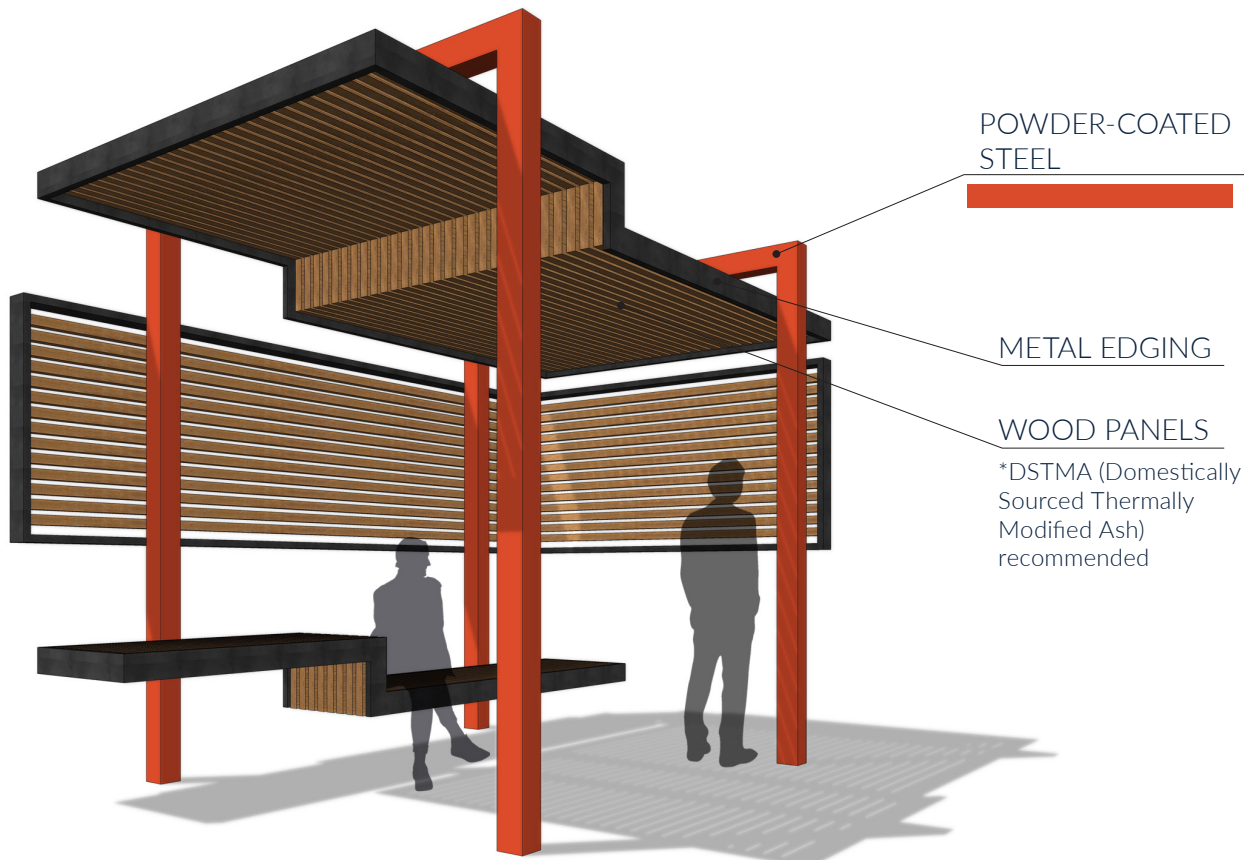

POWDER-COATED STEEL

METAL EDGING

WOOD PANELS

\*DSTMA (Domestically Sourced Thermally Modified Ash) recommended

\*If City policy mandates, transversal bars or armrests can be added to benches to comply

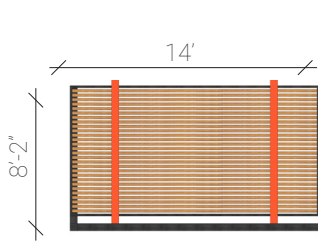

TOP

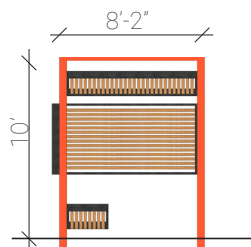

LEFT

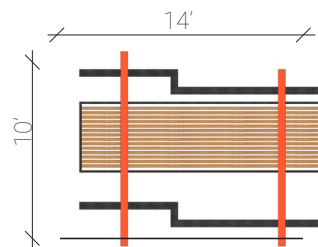

FRONT

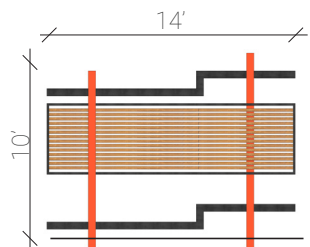

BACK

# FURNISHINGS

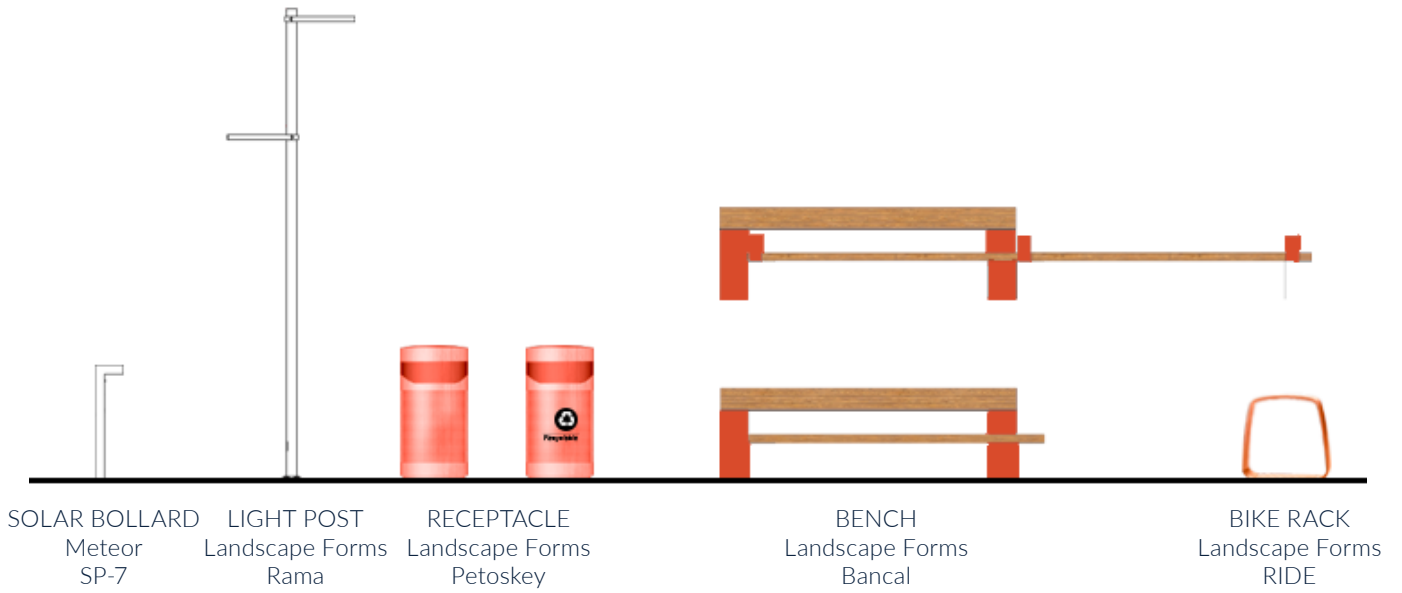

\*Character Area colors will also apply to other elements out of the scope of this project, such as water fountains, components of restroom enclosures, etc. Actual details on these to be developed by each construction project.

# ALTERNATES



WRAP AROUND, STEP-DOWN



SIDE SCREEN, DOUBLE-WIDTH, ADDITIONAL BENCH

# FURNISHINGS FAMILY

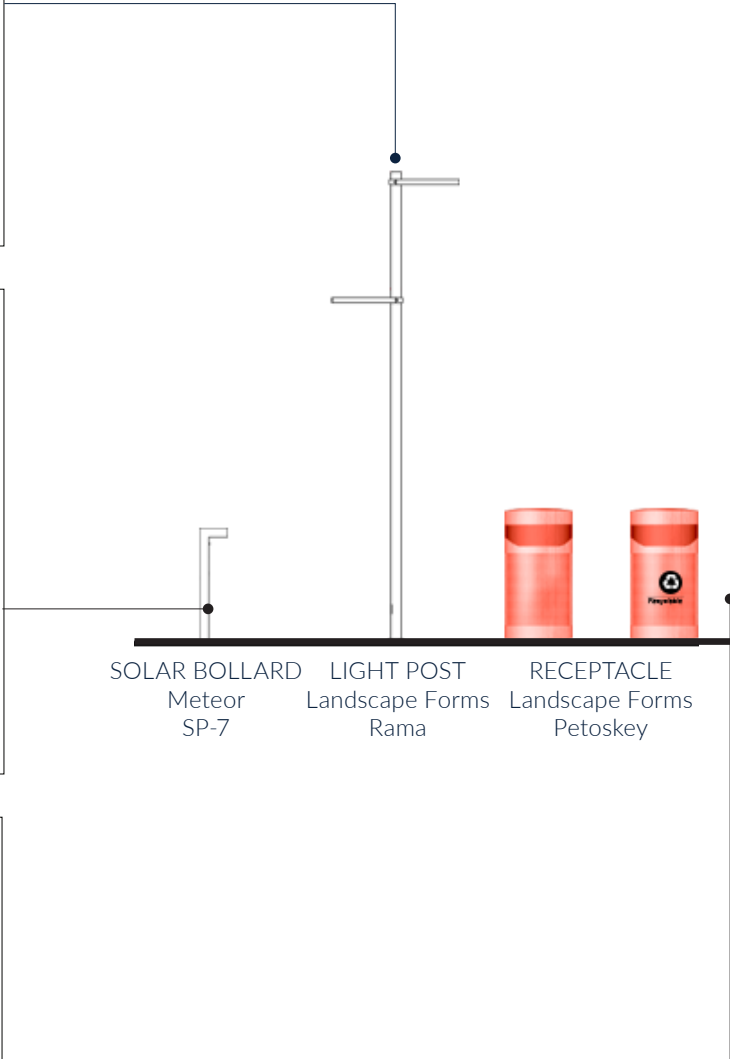

SOLAR BOLLARD	LIGHT POST	RECEPTACLE
Meteor	Landscape Forms	Landscape Forms
SP-7	Rama	Petoskey



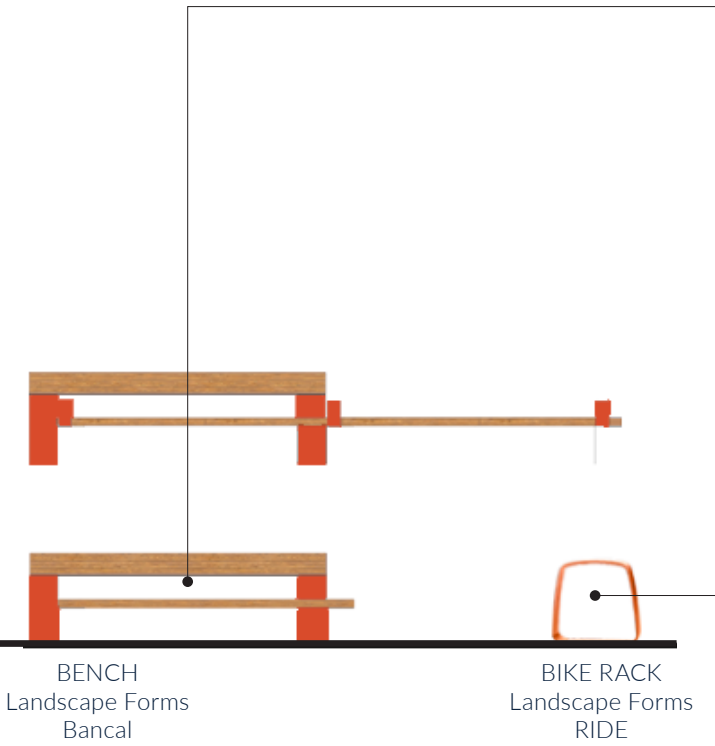

\*Backless Landscape Forms Bancal benches will be paired with this picnic table option

Landscape Forms Bancal  
Tropical wood oil finish

# 6.7 SOLAR ORIENTATION

## SHADE STUDIES

Due to the nature of the floodplain environment, long stretches of the Greenway system are exposed to the sun. Shade structures at strategic locations offer respite to the greenway system user. However, each structure will be individually located by a designer as funding becomes available.

Several shade structure simulations were run to determine the ideal solar orientation (not every shade structure was simulated). The results indicate that structures should generally have their massing face south. A rotation angle of 150-210 degrees from true south generally provides the most shade and is recommended for all future shade structures constructed along the Greenway system.

# SHADE STUDY: LEON CREEK

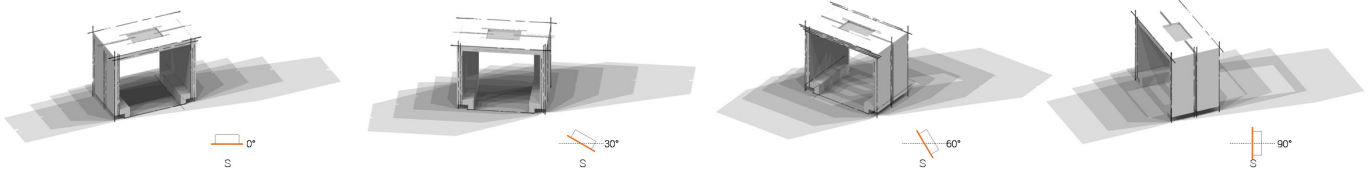

Most Protected Orientations

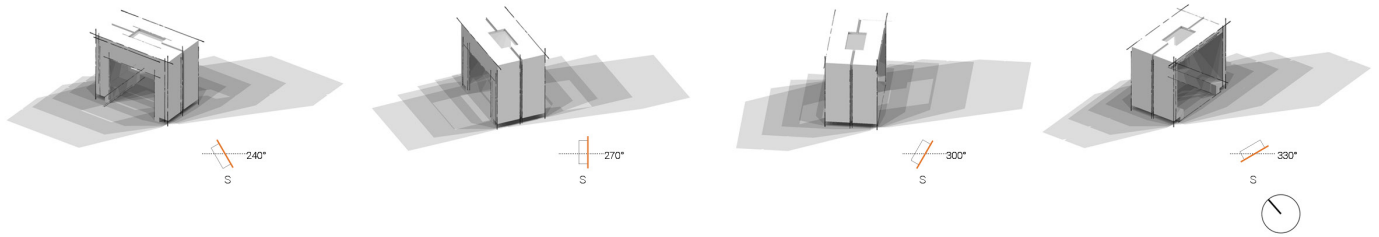
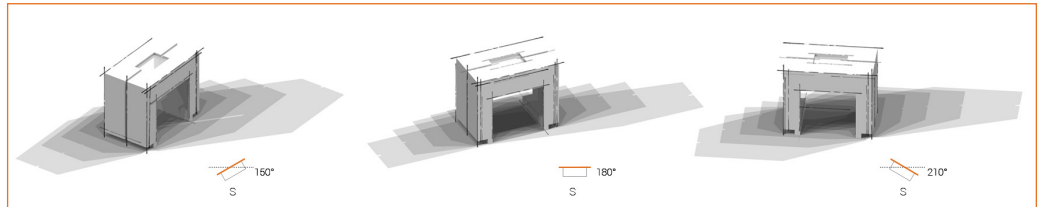

# SHADE STUDY: SALADO CREEK

Most Protected Orientations

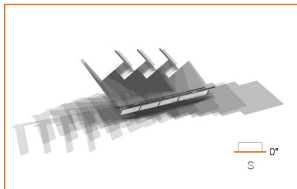

Most Protected Orientations

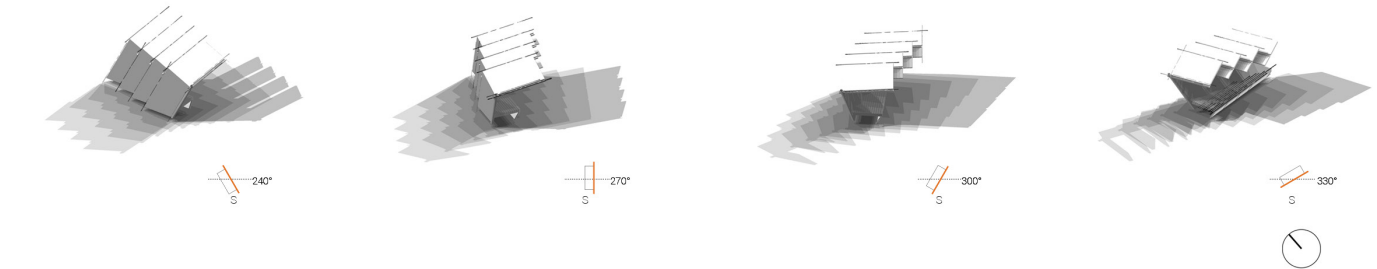
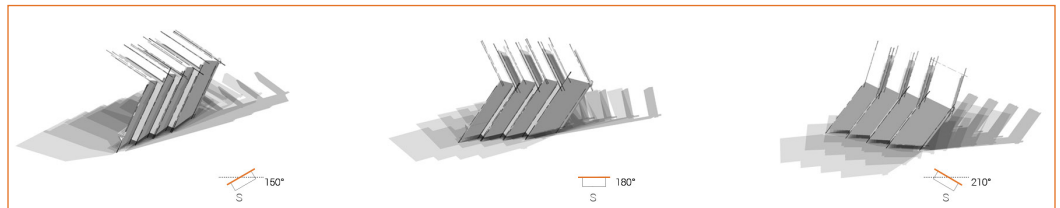

# 6.8 HARDSCAPE TOOLKIT

## PAVING AND STRIPING

In order to give city staff the most flexibility, this Trail Design Strategy proposes several a la carte features that can be added on to the baseline standards. These features can be used with any Trail Capacity width.

- 1. Lane Striping:** The striping indicated in this document has been used as a pilot project in areas with high levels of user conflict. The green and yellow-colored thermoplastic paint consists of lane dividers, chevron directional indicators, and “keep right” text. This tool can be used at the discretion of staff where there is a perception of overcrowding.
- 2. Training Trail:** A training trail can help San Antonio competitive runners achieve their long distance training goals. City staff can determine the best location and distance for a training trail and promote its use to the public. One of the following standard race distances can be used to plan a training trail: 10k, Half Marathon, Marathon.



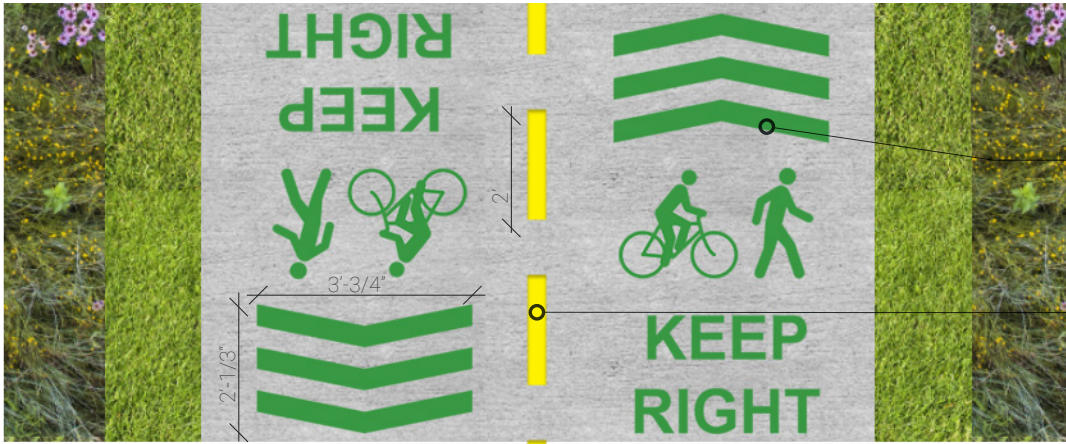

GREEN  
THERMOPLASTIC  
DIRECTIONAL  
STRIPING

YELLOW  
THERMOPLASTIC  
LANE STRIPING

### LANE STRIPING

- CAN BE USED ON ALL TRAIL CAPACITY WIDTHS
- FOR USER CONFLICT AREAS (CITY STAFF TO DETERMINE)

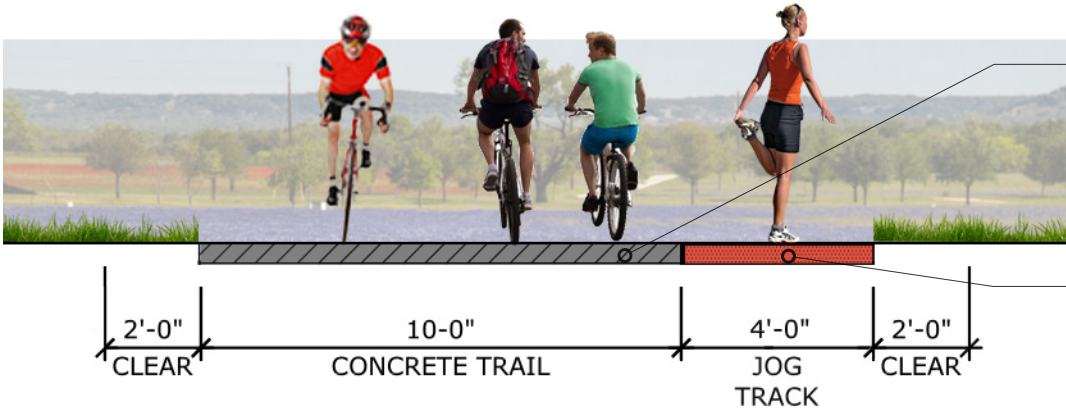

CONCRETE, MEDIUM  
BRUSH

- CONTROL JOINTS AND  
EXPANSION JOINTS TO BE  
DETERMINED BY SOIL TYPES

POLYMERIC ALL-  
WEATHER RUNNING  
TRACK



### TRAINING TRAIL

A training trail can help achieve San Antonio runner's achieve their long distance running goals. One of the following standard race distances can be used to plan a training trail:

- 5K
- 10K
- Half Marathon
- Marathon

City staff can determine the best location and distance for a training trail based on future specific assessment of demand

## IN-GRADE SIGNS

In order to increase a sense of place and user's orientation, this Trail Design Strategy recommends the use of in-grade signs. These features will provide better communicate major street crossings and spur trails that lead to important facilities, such as Tier 1 trailheads. These features entail an in-grade paver band that spans the width of the trail with sandblasted lettering in the concrete indicates the name of the upcoming street or trailhead. Optionally, this impression in the concrete can be filled with a colored epoxy or paint that matches the color of its respective Character Area.

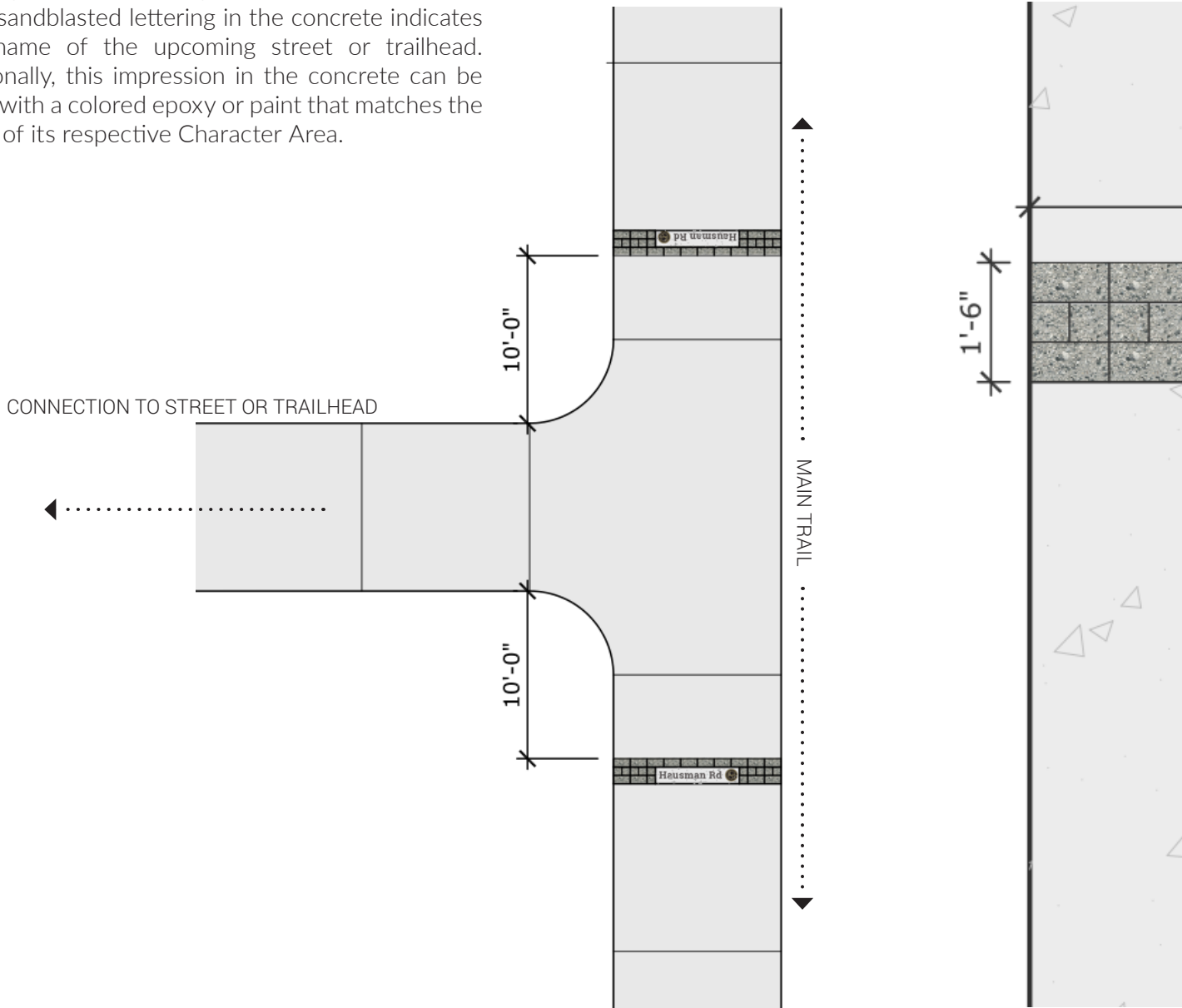

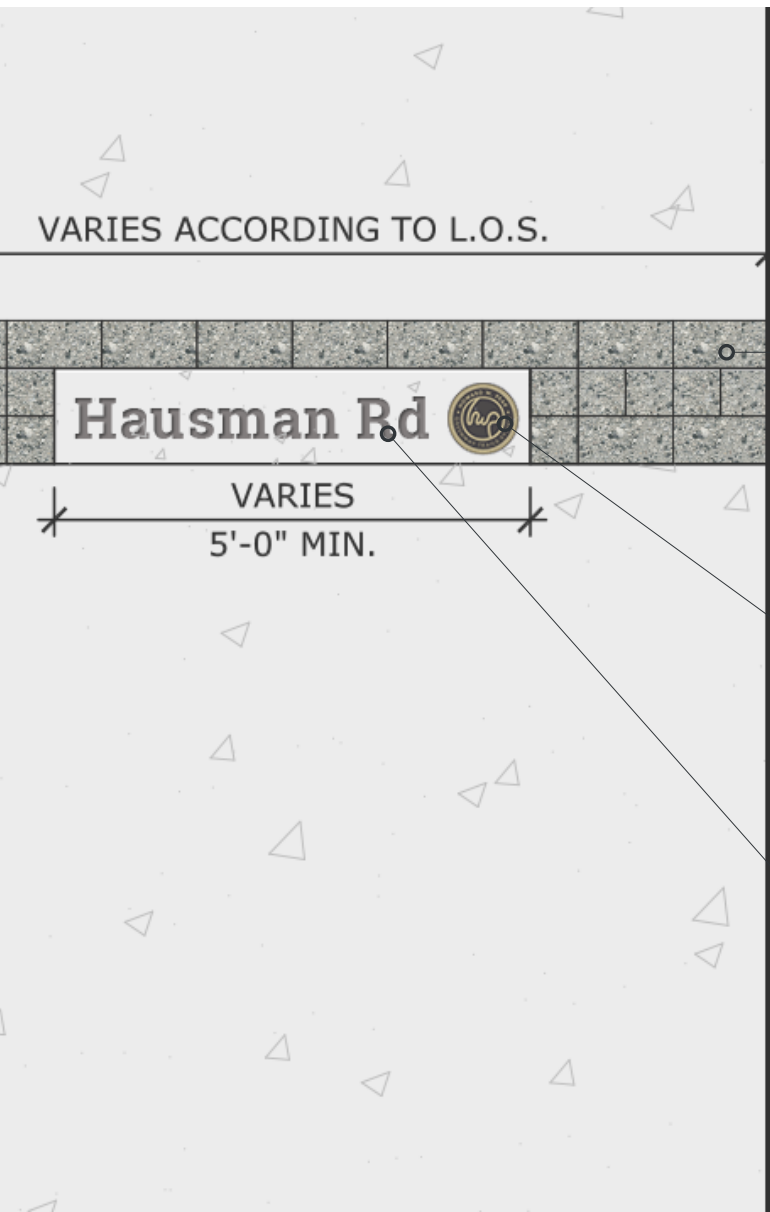

6"X6" AND 6"X12" GRAY GRANITE PAVERS



METAL TRAIL SYSTEM EMBLEM IN CONCRETE



SANDBLASTED LETTERING SIGNIFIES TRAILHEADS AND MAJOR ROADS



- FILLED WITH CUSTOM COLOR EPOXY SIGNIFYING CHARACTER AREA

- EXAMPLE PHOTO LOCATED IN CONFLUENCE PARK



## EXISTING RETAINING WALLS

There are a number of existing retaining wall types being used throughout the trail system, including stamped concrete with animal and plant representations, gunnite walls, stacked limestone, and plain concrete.

Walls recommended to be discontinued:

- Gunnite Walls- typically used for pools.
- Walls with non-unified imprints
- Walls that represent natural scenes



Concrete scene wall



Gunnite wall

## PROPOSED RETAINING WALLS

### GRAVITY WALLS- BOARD FORM AND STAMPED COLOR CONCRETE

Most common wall type along the existing trail system. Due to height restrictions, this wall depends on its own weight for required stability. Gravity walls require footings below finished grade, so height of the retaining wall will affect the size of the footings. Most flatwork contractors installing trails can construct this type of retaining wall successfully, which makes it a cost-effective option. Staining and/or stamping concrete can be used to create contrast for wayfinding, notification, or aesthetics. Follow CoSA standard details for thickness, reinforcing, drainage, and concrete standards.

### GABION WALLS

Natural appearance and cost-effective retaining walls that can be adapted to various grades, existing materials, vegetation, and drainage outfalls. Gabion walls are effective in most heights and can be stair-stepped to heights over 20'. They can be used in areas with significant grade changes and unstable soil. Gabion walls can be used to hinder erosion, dissipate energy from flowing water, and support drainage structures. The voids between the aggregate in the gabion wall allow water to drain freely, assisting with erosion and sedimentation. Gabion walls conform to ground movement making them a great option where movement may be an issue.



Board form concrete



Stamped color concrete



Gabion wall



## CRIB WALLS

Walls are constructed from precast concrete components that interlock to form an open grid. The open spaces are filled with free draining gravel. Vegetation can easily integrate into the wall, which provides an aesthetically pleasing appearance. Crib walls are effective in various heights and can easily transition to match existing grades. Crib walls can serve multiple purposes, the materials are readily available, and are designed to be free draining. Crib walls require increased maintenance as compared to standard cast-in-place retaining walls. Significant toe down depth is required for crib wall applications and may require a reinforced concrete footing.



**Initial Cost**  
\$\$

Crib wall

## LIMESTONE QUARRY BLOCK

Limestone quarry block retaining walls, also called “butter block”, are commonly used on the Greenway and are recommended for continued use. Blocks are typically sawed at the ends and have a rough face on the sides that are adjacent to soil or public facing. They are an economical and attractive solution for retaining walls, and can integrate stairs, ledges, and tiers easily. With the appropriate height and batter, they easily function as seat walls and would be appropriate adjacent to Tier I and II trailheads.



**Initial Cost**  
\$-\$\$

Limestone Quarry Block

## RETAINING WALL BRANDING

A unified theme of hardscape branding would help convey to users that they are on the Howard W. Peak Greenway Trail System. Furthermore, trail users would benefit from additional vertical branding opportunities that horizontal branding, such as the in-grade trail marker. This greenway’s emblem, combined with the name of the corresponding Character Area, can be applied consistently to every type of retaining wall.

CREEK CHARACTER AREA AND  
METAL EMBLEM SET INTO  
CONCRETE RETAINING WALL



## 6.9 LOW IMPACT DEVELOPMENT TOOLKIT

The HWP Greenway System is located almost entirely within floodplains of the waterways which they follow. To protect water quality, mitigate the effects of flooding, and improve ecosystem function, it is important to incorporate “Green Infrastructure” elements in future trail design and improvements.

Low Impact Development (LID) refers to landscape elements which use natural systems for water infiltration, detention, and retention to minimize negative impacts of development near water bodies. These methods can be adapted to a wide variety of contexts and climates, however the central principles remain consistent.

## BIORETENTION BASIN

Bioretention basins are landscaped depressions that intercept stormwater runoff from adjacent paved surfaces to temporarily store, filter, and infiltrate it in 2-4 feet of soil.

They are commonly placed alongside or into parking lots, where they help remove suspended solids, heavy metals, and other pollutants from the lot's stormwater runoff through a mix of physical, biological, and chemical processes. In addition to these filtration capabilities, bioretention basins can effectively reduce peak runoff rates and volumes for relatively frequent storms.

Bioretention basins are well suited for use in small areas, and can be integrated naturally into landscaping to enhance aesthetics and provide habitat for butterflies and bird species (see Pollinator Habitat). The plants selected for bioretention basins must be capable of tolerating both periods of inundation and drought.

Bioretention basins may be best suited in congregating areas such as trail heads, street or neighborhood access points, and rest areas. Underdrain or overflow systems may be considered for areas receiving increased run-off levels. Bioretention areas are beneficial for areas that are hard to drain or commonly hold water.



Typical application

 **Initial Cost**  
|  
\$-\$\$

 **Maintenance**  
|  
High

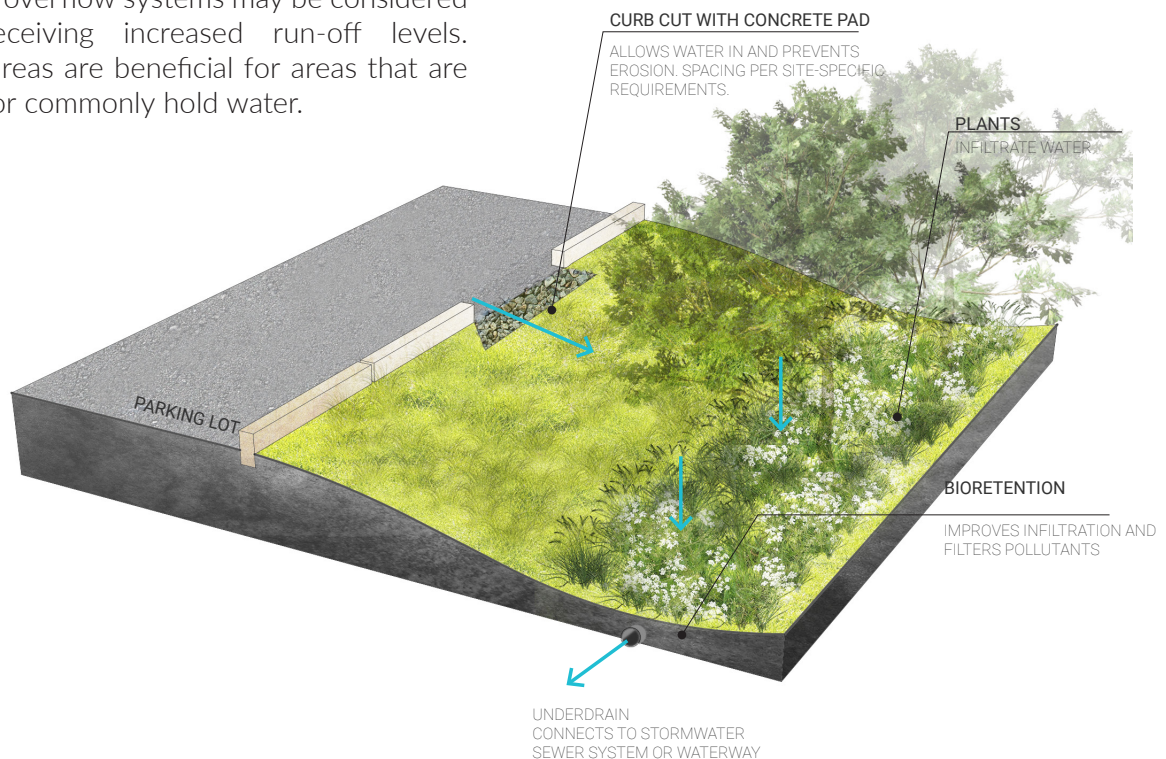



## BIOSWALE

Bioswales are similar to bioretention areas in that they are vegetated, shallow depressions that capture and temporarily store runoff, however, they are designed to be narrow and linear. The collected runoff is intended to remain for 12 to 48 hours.

Similar to bioretention areas, they treat stormwater runoff by vertical filtration through soil media into underlying soils or convey the water via underdrain to stormwater control systems. While they can serve conveyance purposes, their primary objective is to infiltrate water into the ground and improve water quality.

Their linear form makes them well-suited for use along linear impervious surfaces, such as trails, sidewalks, and parking lots.

Underdrain or overflow systems may be considered for areas receiving increased run-off levels. Bioswale depth should be considered to accommodate plant survivability, reduce mosquito habitat, minimize clogging



Typical application

 **Initial Cost**  
\$-\$\$

 **Maintenance**  
High

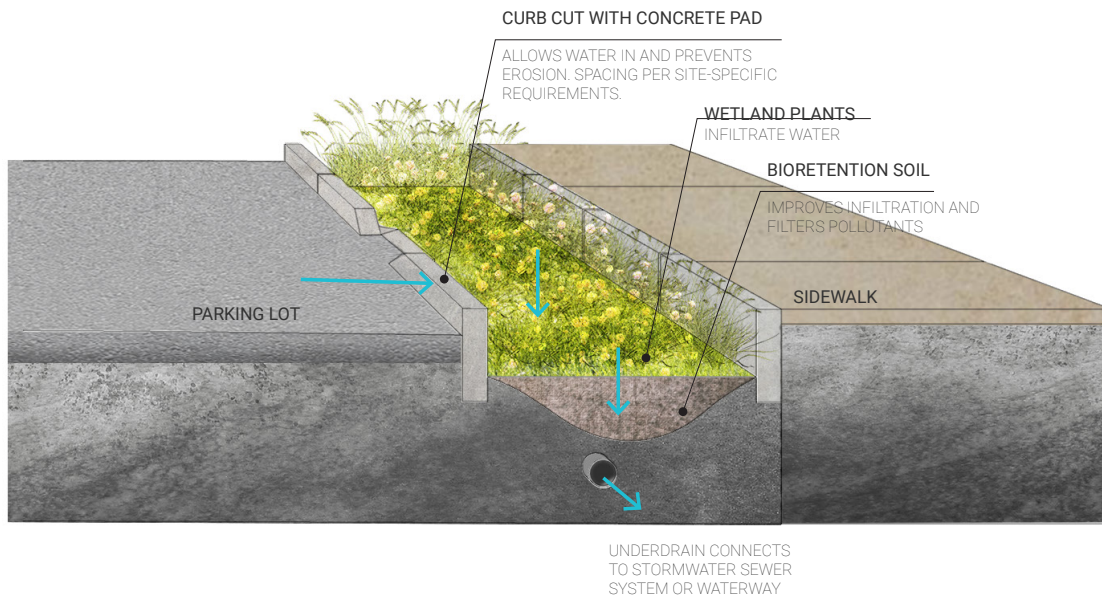



## VEGETATED SWALE

Reduction in bank erosion and re-meandering to restore the natural shape of the river and reduce water velocity to improve sediment movement. Chemical function improvements may include a reduction of stormwater pollution inputs through the planting of a vegetated riparian buffer. Improvements in biological function may include the planting of species that provide habitat and food for aquatic fish, insects, and other wildlife. The restoration of the riparian zone, or the area surrounding the open water, helps filter pollutants out of stormwater runoff before it reaches the water. Healthy riparian zones improve habitat, stabilize water channels and stream banks, improve water quality, provide stream shade and temperature control, and improve aesthetics.



Typical application

 **Initial Cost**  
\$

 **Maintenance**  
Low

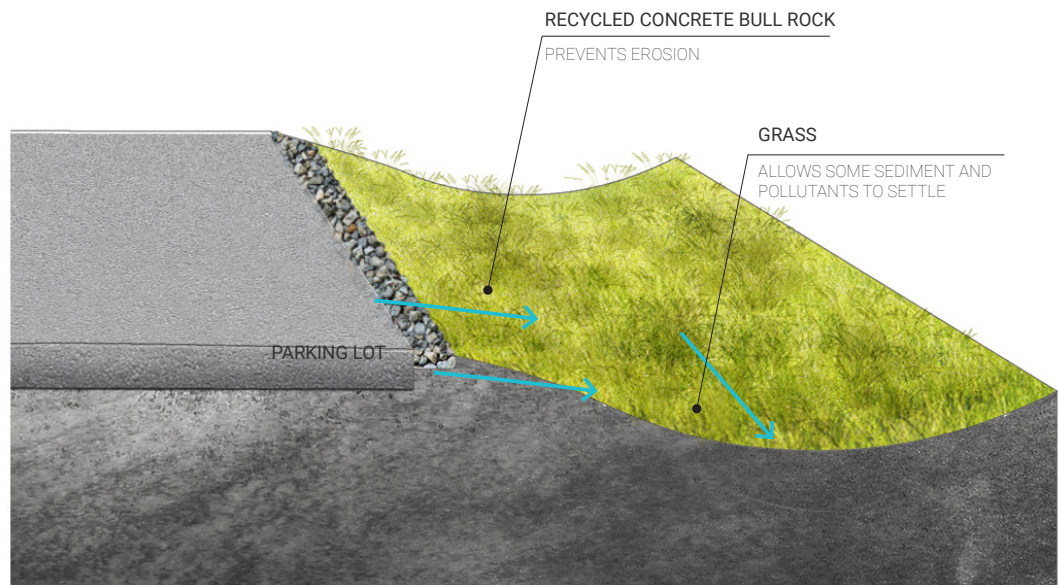

## VEGETATED FILTER STRIP

Vegetated filter strips are bands of vegetation along a uniform slope that pre-treat runoff from impervious areas before it flows into another LID feature. They help improve stormwater quality and reduce runoff flow velocity through horizontal filtration, however, they are not meant to act as a standalone and are used as pretreatment devices for other, larger-capacity LID features, such as bioretention areas. While they are effective at reducing flow speeds and removing sediment and particulate-bound pollution, they do not provide significant volume reduction. They are often used for treating runoff from roads, highways, driveways along streams to filter water before it reaches riparian areas. They are highly adaptable solutions that are visually similar to landscaping beds.



Typical application

 **Initial Cost**  
\$

 **Maintenance**  
Low

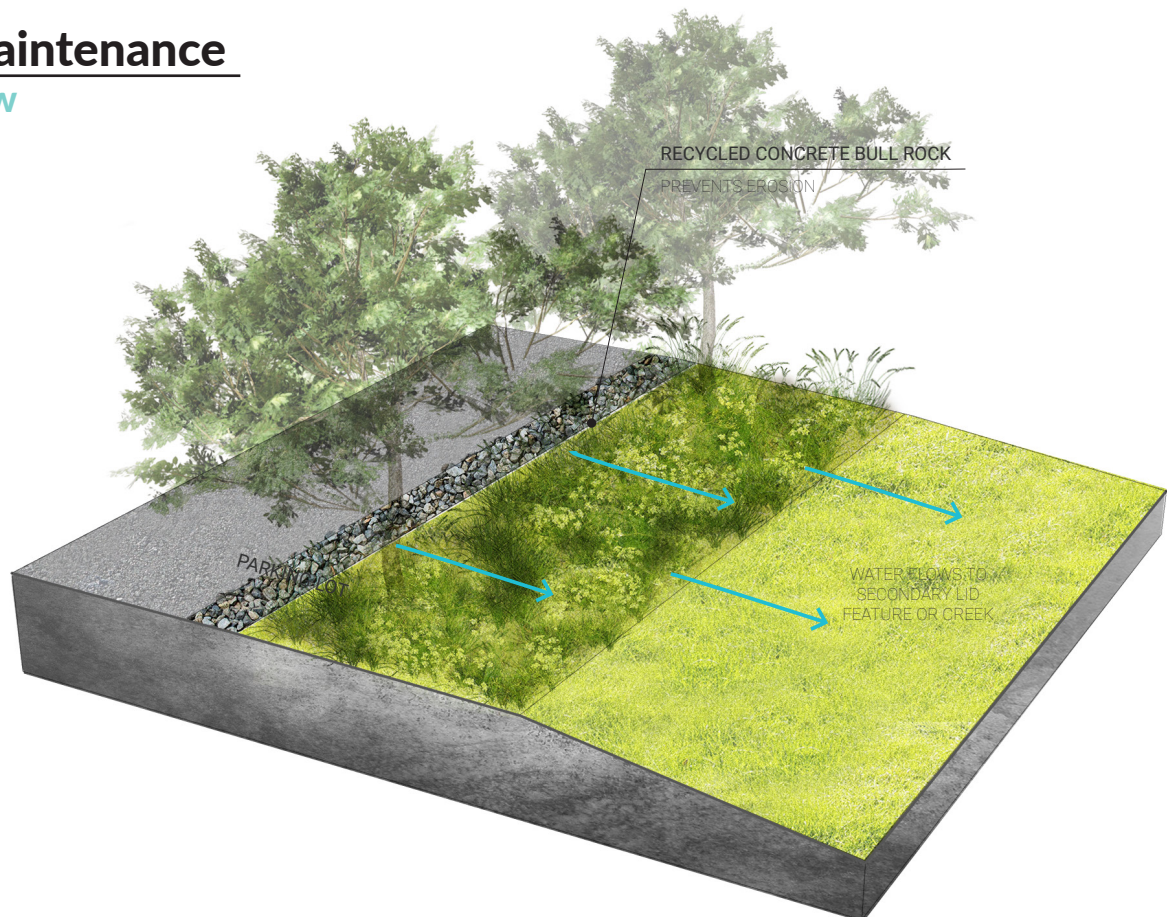



## PERMEABLE HARDSCAPES

Permeable surfaces are an alternative to traditional impervious surface materials, such as concrete and asphalt. Permeable surface treatments have small voids or aggregate-filled joints that allow water to drain to a layer of open-grade aggregate, where it either infiltrates into the ground or is conveyed via underdrain to stormwater control systems if soil infiltration is low.

The following systems are recommended for consideration at Tier I trailheads in every character area.

### PERMEABLE/POROUS SURFACES

A successful permeable surface (paver, pervious concrete, or porous asphalt) will need to consider structural and hydrological design. The structural design will need to consider the pavement strength required to accommodate bicycle, maintenance, and utility vehicle loading. The hydrological design will need to consider the capacity required to infiltrate, store, and release water in a manner that positively contributes to water quality and stormwater management.

### PERVIOUS PAVERS

Pavers can be placed in areas to create contrast for wayfinding, notification, or aesthetics. Can be utilized along trail system, near shade or rest areas, parking areas or in transition areas. Product is used universally in San Antonio, which is appealing for various usages and locations along the trail system. Pervious pavers assist in filtering stormwater pollutants and allow stormwater infiltration.

### PERVIOUS/POROUS CONCRETE

Porous/pervious pavement is ideal for Tier I trailheads. The most successful applications are in areas where regular maintenance can be performed to ensure positive performance. Pervious pavement assists in filtering stormwater pollutants and allows stormwater infiltration. Not effective when adjacent to other pervious areas or if receiving high levels of sediment/debris. May require a drainage system to convey water. Large and/or high-traffic areas will require structural design. This option can be desirable for rest areas as the porous pavement absorbs and stores less heat than conventional concrete creating positive impacts for users and the environment.

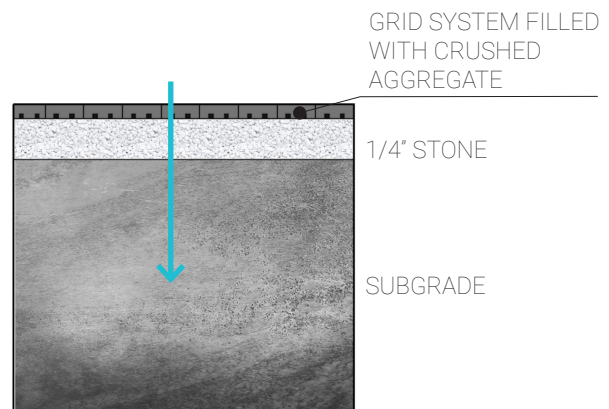
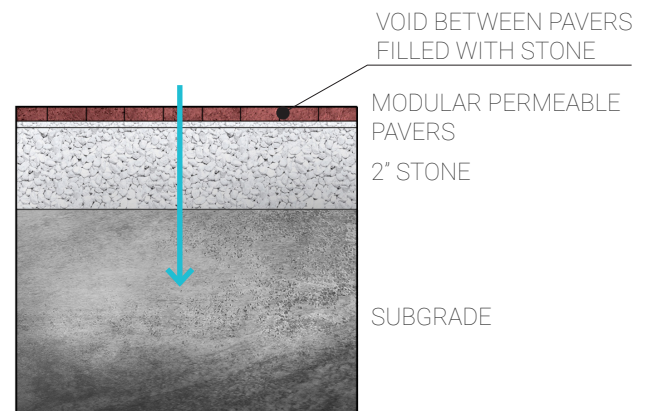
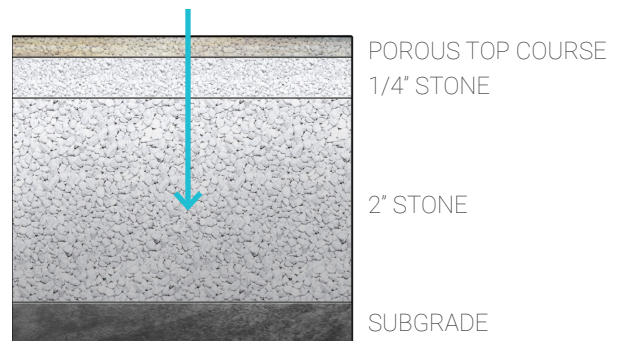

## OTHER LID OPPORTUNITIES

### RIPARIAN RESTORATION

When a stream's functions have been compromised relative to its natural potential or historic functions, the stream is considered to be degraded or disturbed. Stream restoration is the attempt to restore physical, chemical, and biological functions of a stream system. Physical function improvements may include a reduction in bank erosion and re-meandering to restore the natural shape of the river and reduce water velocity to improve sediment movement. Chemical function improvements may include a reduction of stormwater pollution inputs through the planting of a vegetated riparian buffer. Improvements in biological function may include the planting of species that provide habitat and food for aquatic fish, insects, and other wildlife. The restoration of the riparian zone, or the area surrounding the open water, helps filter pollutants out of stormwater runoff before it reaches the water. Healthy riparian zones improve habitat, stabilize water channels and stream banks, improve water quality, provide stream shade and temperature control, and improve aesthetics.



### PLANTING CONSIDERATIONS

The “Pollinator Plant List” on page 107 and “Recommended Trees” on pages 108 and 109 are high priority considerations for future plantings on the Greenway. However, site-specific considerations should inform a more detailed analysis of plant selection. The following considerations should be taken into account at that time:

- Plants with longer blooming periods tend to have higher nectar production and more showy blooms.
- Drought-tolerant plants should be prioritized over anything necessitating irrigation.
- Plants which can re-seed themselves, such as pink evening primrose, tend to be easier to manage long-term and are more resilient.
- Plants which are native to Bexar County, surrounding counties with similar climate, and areas in Texas with slightly dryer and hotter conditions should be prioritized because of their tolerance of the current and future regional climate.
- Plant with little to no maintenance needs should be prioritized over plants with extensive and regular maintenance needs.



## POLLINATOR PLANTING

Vegetated LID features, such as bioswales, vegetated filter strips, riparian restoration, and bioretention areas, can serve the dual purpose of providing stormwater management and pollinator habitat and forage. Native Texas pollinators, such as hummingbirds, bees, and butterflies, provide critical services to the state of Texas and the country at large - three quarters of the most common human food crops require pollination. The flowers of plants used within vegetated LID features can provide nectar and pollen to these important animals. Because many Texas pollinators evolved for thousands of years alongside plants native to the area, native Texas plants should be prioritized

in LID features over non-native species. To further support important pollinator habitat, plantings should be planted in clumps and layers using trees, shrub layers, and low-growing perennials intermixed with flowering annuals. This diversity in vegetation provides many sheltered niches for pollinators to utilize as both nesting and loafing areas, such as the following:

## POLLINATOR PLANT LIST



**Scarlet sage**  
*Salvia coccinea*  
Pollinators: Hummingbirds,  
Butterflies, Bees

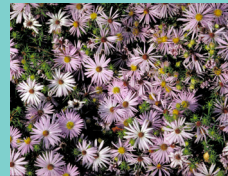

**Fall aster**  
*Symphyotrichum oblongifolium*  
Pollinators: Birds, Butterflies



**Blue mistflower**  
*Conoclinium coelestinum*  
Pollinators: Hummingbirds,  
Butterflies, Bees



**Rock rose**  
*Pavonia lasiopetala*  
Pollinators: Bees



**Snake herb**  
*Dyschoriste linearis*  
Pollinators: Butterflies



**Texas spiderlily**  
*Hymenocallis liriosme*  
Pollinators: Insects

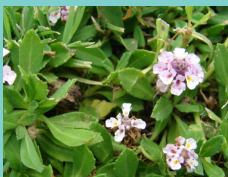

**Frogfruit**  
*Phyla nodiflora*  
Pollinators: Numerous,  
Butterflies



**Mealy blue sage**  
*Salvia farinacea*  
Pollinator: Bees



**Pink evening primrose**  
*Oenothera speciosa*  
Pollinators: Birds



**Tick seed**  
*Coreopsis* spp.  
Pollinators: Butterflies, Bees,  
Birds

 Plants appropriate for some LID features

## RECOMMENDED TREES

Trees are a critical feature of stormwater management practices and low impact development. They intercept rainfall, direct precipitation into the ground, and absorb stormwater through their roots.

Their roots also penetrate soil layers to break up compacted soils and increase storm water infiltration rates. Trees also help reduce sediment runoff into streams, and if planted stream-side can moderate water temperatures, which protects sensitive species. They create a cooling environmental effect by releasing water through their leaves and back into the atmosphere in a process called evapotranspiration. Additional benefits to human comfort include shade, carbon sequestration, and air pollution mitigation.

**Sun Needs**

-  Sun
-  Part Shade
-  Shade

**Soil Moisture**

- D- Dry
- M - Moist
- W- Wet



Live Oak  
*Quercus virginiana*

Mesquite  
*Prosopis glandulosa*

Possum Haw  
*Illex decidua*

	Common Name
TALL SHADE TREES 40-60+ Feet	Black Willow
	Bur Oak
	Cedar Elm
	Chinquapin Oak
	Mexican Sycamore
	Hackberry
	Bald Cypress
	Live Oak
	Anaqua
	Pecan
MEDIUM TREES 25-40 Feet	Huisache
	Eve's Necklace
	Mesquite
	Carolina Buckthorn
	Yaupon Holly
SHORT TREES 15-25 Feet	Kidneywood
	Mexican Buckeye
	Rusty Blackhaw
	Texas Mountain Laurel
	Possumhaw



Latin Name	Size	Shade Provision	Sun Needs	Water Needs	Soil Moisture	Riparian Restoration	Bioswale	Bioretention Basin	Vegetated Filter Strip
<i>Salix nigra</i>	L	max. 875 sf	☀️ ☀️ ●	High	M, W	●	●	●	
<i>Quercus macrocarpa</i>	L	max 1200 sf	☀️ ☀️	Medium	D, M				●
<i>Ulmus crassifolia</i>	L	max 875 sf	☀️ ☀️	Medium	M	●	●	●	●
<i>Quercus muhlenbergii</i>	L	max 875 sf	☀️ ☀️	Medium	D				●
<i>Platanus mexicana</i>	L	max 1200 sf	☀️ ☀️	High	D,M,W		●	●	●
<i>Celtis spp.</i>	L	max 875 sf	☀️ ☀️ ●	Low	D, M	●			●
<i>Taxodium distichum</i>	L	max 1200 sf	☀️ ☀️	Medium	M	●	●	●	●
<i>Quercus virginiana</i>	L	max 875 sf	☀️ ☀️	Medium	M				●
<i>Ehretia anacua</i>	L	max 875 sf	☀️ ☀️	Low	D				●
<i>Carya illinoensis</i>	L	max 1200 sf	☀️	High	M				●
<i>Vachellia farnesiana</i>	M	max 550 sf	☀️	Low	D				●
<i>Styphnolobium affine</i>	M	max 875 sf	☀️ ☀️	Low	D	●	●	●	●
<i>Prosopis glandulosa</i>	M	max 250 sf	☀️	Low	D				●
<i>Frangula caroliniana</i>	M	max 250 sf	☀️ ☀️	Medium	M				●
<i>Ilex vomitoria</i>	M	max 125 sf	☀️ ☀️	Medium	M		●	●	
<i>Eysenhardtia texana</i>	S	too short to shade	☀️	Low	D				●
<i>Ungnadia speciosa</i>	S	too short to shade	☀️ ☀️	Low	D				●
<i>Viburnum rufidulum</i>	S	too short to shade	☀️ ☀️	Low	D, M, W		●	●	●
<i>Sophora secundiflora</i>	S	too short to shade	☀️ ☀️	Low	D, M				●
<i>Ilex decidua</i>	S	too short to shade	☀️ ☀️	Medium	M	●	●	●	●

# 6.10 PLACEMAKING INTERVENTIONS

Throughout the trail system, there are many opportunities for artistic expression. Such interventions can offer a sense of place and will elevate the trail as a cultural and heritage destination.

## ART AT BRIDGES

Many low water bridge crossings have vertical concrete structures that are meant to provide edge protection while also allowing water to run over the bridge during flood stage. This infrastructure can be re-imagined by artists both before and after construction of the bridge.



## FOOD TRUCKS (TEMPORARY)

Adding food trucks and temporary additional furnishings can bring in users that normally don't use the trail system and is a great way to make an activity hub at a Tier I trailhead.



## AMPHITHEATER

Amphitheaters can be used for regular performance programming. Seating can incorporate gabions, which compliment nearby retaining walls. In addition, seating can take advantage of topography to create a acoustic "bowl" effect.



## NATURE PLAY

Integrating opportunities for play along the greenway will encourage more families to visit the system. At the same time, it also fosters conservation values for children. Free-form play in wild spaces has been proven to have physical, social, and spiritual benefits. These play areas can flank corridors but would be most utilized at Tier I and II trailheads.





## OVERLOOKS

There are multiple opportunities for “bumpouts” along the greenway, at particularly scenic vantage points such as restoration areas, hill country vistas, or particularly notable bald cypress trees. Special paving materials, artistic metal work, and environmental interpretation signage.



## SITE SPECIFIC ART PIECES

Unique sculptural elements can be an unexpected whimsical addition to trail system. They also provide an excellent photo opportunity.



## LABYRINTH

A labyrinth is an irregular network of passages or paths in which it is difficult to find one’s way. These features can be added to trailheads for visual interest.



## RAMMED EARTH WALLS

Can be used as a “gateway” at Tier II trailheads. Can be integrated into signage system and used in lieu of masonry walls.



## EXERCISE EQUIPMENT

Exercise equipment can be a complementary amenity to trails as they provide opportunities for strength training in addition to the opportunity to focus on cardiovascular health on the trail.







# 7 MASTER MATRIX

The Master Matrix section serves as a resource to understand where and when recommended interventions should be implemented. While many of the site furnishing design features occur primarily at Tier 1 and Tier 2 Trailheads and are specific to certain Character Areas, other features within the hardscape and LID toolkits can occur throughout the Greenway system based on site specific considerations to be determined during a site design phase.

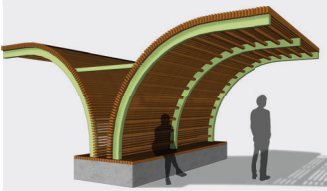
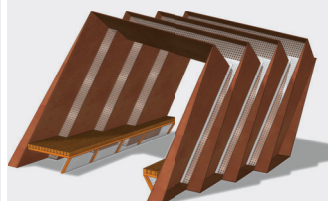
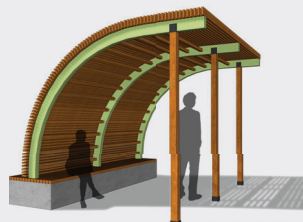



Master Table Matrix		<input checked="" type="radio"/> Recommended <input type="radio"/> Optional			Medina River T-1	Salado Creek-S T-3
		Tier I	Tier II	Corridor		
Trail Feature						
SITE FURNISHINGS	Custom Powdercoat	<input checked="" type="radio"/>	<input checked="" type="radio"/>	<input checked="" type="radio"/>	Bald Cypress Green RAL 6019 RGB 185, 206, 172	Monarch Butterfly Orange RAL 1003 RGB 249, 168, 0
	Shade Structure	\$\$	<input checked="" type="radio"/>		 Page 69	 Page 73
		\$	<input type="radio"/>	<input checked="" type="radio"/>	<input type="radio"/>	 Page 68
	Bench	<input checked="" type="radio"/>	<input checked="" type="radio"/>	<input type="radio"/>	 Landscape Forms Bilateral With backrest and armrests Tropical wood oil finish Steel structure Page 68	 Victor Stanley Freesia FRE-20 (without armrest) Perforated steel panels Page 73
	Picnic Table	<input checked="" type="radio"/>	<input type="radio"/>		 Landscape Forms Grentchen Without umbrella hole Wood: Ipe Page 71	 Victor Stanley Camille CAMT-43 Wood slats Page 75



# Salado Creek- N

T-4

Artesian Blue  
RAL 6027  
RGB 126, 186, 181

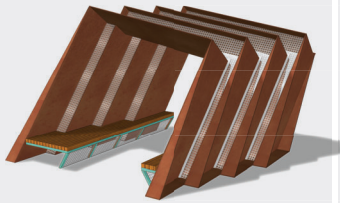

Page 77

# Leon Creek- S

T-3

Air Force Blue  
RAL 5013  
RGB 25, 49, 83

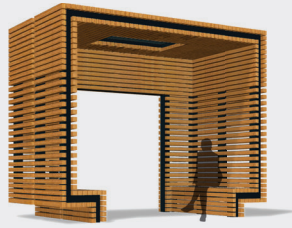

Page 80

# Leon Creek- N

T-4

Prickly Pear Purple  
RAL 4006  
RGB 144, 51, 115

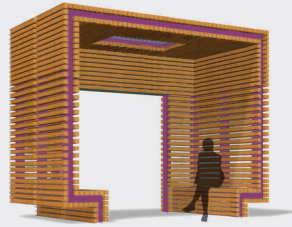

Page 84

# West Side Creeks

T-5

Enchilada Red  
RAL 2010  
RGB 208, 93, 40



Page 88

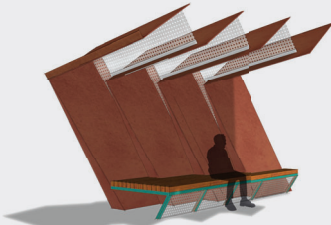

Page 76



Page 81



Page 85



Page 89



Victor Stanley Freesia  
FRE-20 (without armrest)  
Perforated steel panels  
Page 77



Landscape Forms Harpo  
69" narrow wood  
Wood  
Page 81



Landscape Forms Harpo  
69" narrow wood  
Wood  
Page 85



Landscape Forms Bancal  
168" backed offset  
Wood: Ipe  
Page 89



Victor Stanley Camille  
CAMT-43  
Wood slats  
Page 79







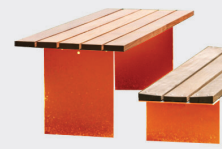

Landscape Forms Harpo  
Narrow slats  
Wood  
Page 83



Landscape Forms Harpo  
Narrow slats  
Wood  
Page 87



Landscape Forms Bancal  
Tropical wood oil finish  
Page 91

Master Table Matrix		<input checked="" type="radio"/> Recommended <input type="radio"/> Optional			Medina River T-1	Salado Creek-S T-3
		Tier I	Tier II	Corridor		
	Trail Feature					
SITE FURNISHINGS	Receptacle	<input checked="" type="radio"/>	<input checked="" type="radio"/>	<input type="radio"/>	 Landscape Forms Petoskey 30 gal. hinged lid Perforated panel Page 69	 Victor Stanley Dynasty DYN-242 Recycled solid steel bar Page 73
	Bike Rack	<input checked="" type="radio"/>	<input type="radio"/>		 Landscape Forms RIDE Page 69	 Victor Stanley Freesia BFRE-101 Page 73
	Light Post	<input checked="" type="radio"/>	<input type="radio"/>		 Landscape Forms RAMA Page 69/73/77/81/85/89	
	Light Bollard	<input checked="" type="radio"/>	<input type="radio"/>	<input type="radio"/>	 Meteor SP-7 Page 69/73/77/81/85/89	

# Salado Creek- N

T-4



Victor Stanley Dynasty  
DYN-242  
Recycled solid steel bar  
Page 77

# Leon Creek- S

T-3



Landscape Forms Petoskey  
30 gal. hinged lid  
Perforated panel  
Page 81

# Leon Creek- N

T-4



Landscape Forms Petoskey  
30 gal. hinged lid  
Perforated panel  
Page 85

# West Side Creeks

T-5



Landscape Forms Petoskey  
30 gal. hinged lid  
Perforated panel  
Page 89



Victor Stanley Freesia  
BFRE-101  
Page 77



Landscape Forms  
RIDE  
Page 81



Landscape Forms  
RIDE  
Page 85



Landscape Forms  
RIDE  
Page 89



Landscape Forms  
RAMA  
Page 69/73/77/81/85/89

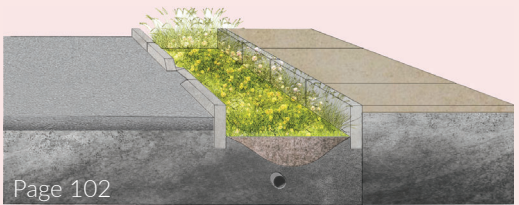
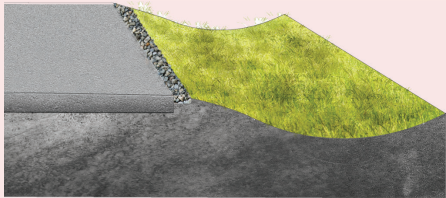
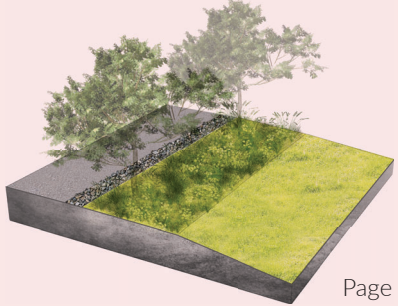
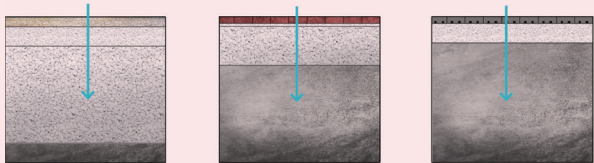

Meteor  
SP-7  
Page 69/73/77/81/85/89

Master Table Matrix		<input checked="" type="radio"/> Recommended <input type="radio"/> Optional			Medina River T-1	Salado Creek-S T-3
		Tier I	Tier II	Corridor		
Trail Feature						
SITE FURNISHINGS	Bioretention Basin	<input checked="" type="radio"/>	<input type="radio"/>			Page 101
	Bioswale	<input checked="" type="radio"/>				Page 102
	Vegetated Swale	<input checked="" type="radio"/>	<input type="radio"/>			Page 103
	Vegetated Filter Strip	<input checked="" type="radio"/>	<input checked="" type="radio"/>	<input checked="" type="radio"/>		Page 104
	Permeable Hardscapes	<input checked="" type="radio"/>	<input type="radio"/>		 Permeable/Porous Surfaces    Pervious Pavers    Pervious/Porous Concrete	



Salado Creek- N  
T-4

Leon Creek- S  
T-3

Leon Creek- N  
T-4

West Side Creeks  
T-5

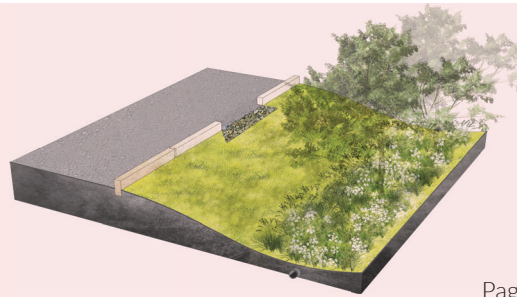

Page 101

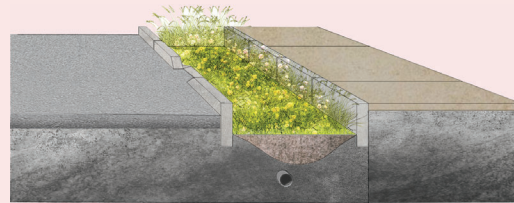

Page 102

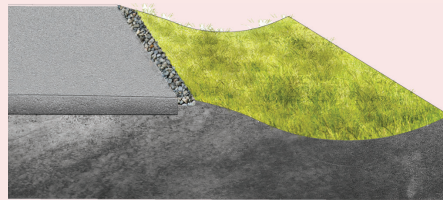





Page 103

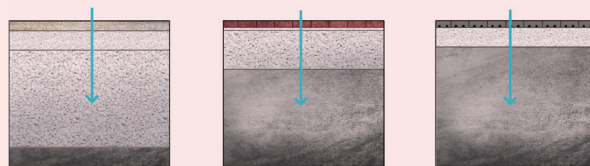

Page 104



Permeable/Porous Surfaces Pervious Pavers Pervious/Porous Concrete Page 105

Master Table Matrix		<input checked="" type="radio"/> Recommended <input type="radio"/> Optional			Medina River T-1	Salado Creek-S T-3
		Tier I	Tier II	Corridor		
SITE FURNISHINGS	Trail Feature					
	Future Ideal Trail Width			<input checked="" type="radio"/>	10'	10'
	Lane striping			<input type="radio"/>	 Page 95	
	Training trail			<input type="radio"/>	 Page 95	
	In-grade sign			<input checked="" type="radio"/>	 Page 97	
Retaining Walls	<input type="radio"/>	<input type="radio"/>	<input type="radio"/>	 Gabion Page 98      Crib Wall Page 99		

<b>Salado Creek- N</b> T-4	<b>Leon Creek- S</b> T-3	<b>Leon Creek- N</b> T-4	<b>West Side Creeks</b> T-5
12'	10'	14'	12'



Page 95



Page 95



Page 97

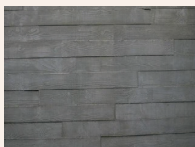

Board Form  
Concrete  
Page 98



Limestone Quarry Block  
Page 99



